

## Test Verification of Conformity

On the basis of the referenced test report(s), the sample(s) of the below product has been found to comply with the relevant harmonized standard(s) to the directive(s) listed on this verification at the time the tests were carried out. The manufacturer may indicate compliance to only the said directives by signing a DoC himself and may affix the CE marking to products identical to the tested sample(s) if the product complies with all CE marking directives that has the product in their scope. In addition, the manufacturer shall file and keep the documentation according to the rules of the applicable directive(s) and shall consider changes of the standards as they may occur. Additional requirements, additional directives and local laws may be applicable.

<b>Applicant Name &amp; Address</b>	: Eaglerise Electric & Electronic (China) Co., Ltd. Guicheng Sci-Tech Industrial Park, Jianping Road, Nanhai District, Foshan City, Guangdong Province, P. R. China
<b>Product(s) Tested</b>	: a.c. supplied electronic controlgear for LED modules (LED driver)
<b>Ratings and principal characteristics</b>	: See page 2
<b>Model(s)</b>	: See page 2
<b>Brand name</b>	:  EAGLERISE
<b>Relevant Standard(s) / Specification(s) / Directive(s)</b>	: EN 55015: 2006+A1: 2007+A2: 2009/ Limits and methods of measurement of radio disturbance characteristics of electrical lighting and similar equipment  EN 61000-3-2: 2006+ A1: 2009+ A2: 2009/ Electromagnetic compatibility (EMC) – Part 3-2: Limits – Limits for harmonic current emissions (equipment input current ≤ 16 A per phase)  EN 61000-3-3: 2008/ Electromagnetic compatibility (EMC) – Part 3-3: Limits – Limitation of voltage changes, voltage fluctuations and flicker in public low-voltage supply systems, for equipment with rated current ≤ 16 A per phase and not subject to conditional connection  EN 61547: 2009/ Equipment for general lighting purposes – EMC immunity requirements  EMC Directive 2004/108/EC
<b>Verification Issuing Office Name &amp; Address</b>	: Same as Legal Entity
<b>Verification/Report Number(s)</b>	: 130105062GZU-001/130105062GZU-001:2013-3-29

**Note 1 :** This verification is part of the full test report(s) and should be read in conjunction with it.

This Verification is for the exclusive use of Intertek's Client and is provided pursuant to the agreement between Intertek and its Client. Intertek's responsibility and liability are limited to the terms and conditions of the agreement. Intertek assumes no liability to any party, other than to the Client in accordance with the agreement, for any loss, expense or damage occasioned by the use of this Verification. Only the Client is authorized to copy or distribute this Verification. Any use of the Intertek name or one of its marks for the sale or advertisement of the tested material, product or service must first be approved in writing by Intertek. The observations and test results referenced from this Verification are relevant only to the sample tested. This Verification by itself does not imply that the material, product, or service is or has ever been under an Intertek certification program.

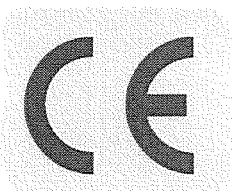

Signature

Name: Carrie Chen  
 Position: Technical Supervisor  
 Date: 29 March 2013

## Annex to Test Verification of Conformity

This is an Annex to Test Verification of Conformity with Verification/Report Number(s): 130105062GZU-001/130105062GZU-001. The issuing office is Intertek Testing Services Shenzhen Ltd. Guangzhou Branch (Address: Block E, No, 7-2 Guang Dong Software Science Park, Caipin Road Guangzhou Science City, GETDD Guangzhou).

**Ratings and principal characteristics**

: Input: 220-240 VAC; 50/60 Hz; 0,21 A; Class II; IP 20; SELV;  
ta 50 °C; tc 80 °C; Independent type; 110 °C thermal protection;  
Inherently short-circuit proof;  
Output: Constant current type;  
MM mark;  
Suitable for direct mounting on normally flammable surfaces;

**Model(s)**

ELP036C\*\*\*\*LSD1  
The 1st to 4th “\*” indicate the output current of LED driver; can be replaced by “0500” to “1000” and increasing in multiplies of 100. “0500” means 500 mA; “1000” means 1000 mA

**Note 1: This annex is part of the Test Verification of Conformity and should be read in conjunction with it.**

This Verification is for the exclusive use of Intertek's Client and is provided pursuant to the agreement between Intertek and its Client. Intertek's responsibility and liability are limited to the terms and conditions of the agreement. Intertek assumes no liability to any party, other than to the Client in accordance with the agreement, for any loss, expense or damage occasioned by the use of this Verification. Only the Client is authorized to copy or distribute this Verification. Any use of the Intertek name or one of its marks for the sale or advertisement of the tested material, product or service must first be approved in writing by Intertek. The observations and test results referenced from this Verification are relevant only to the sample tested. This Verification by itself does not imply that the material, product, or service is or has ever been under an Intertek certification program.



Signature

Name: Carrie Chen  
Position: Technical Supervisor  
Date: 29 March 2013

**TEST REPORT**

Applicant Name & Address : Eaglerise Electric & Electronic (China) Co., Ltd.  
Guicheng Sci-Tech Industrial Park, Jianping Road, Nanhai District, Foshan  
City, Guangdong Province, P. R. China

Manufacturing Site : Same as applicant

Sample Description

Product : a.c. supplied electronic controlgear for LED modules (LED driver)

Model No. : See page 5

Electrical Rating : See page 5

Date Received : 02 February 2013

Date Test Conducted : 02 February 2013-07 March 2013

Test standards : EN 55015: 2006+A1: 2007+A2: 2009  
EN 61000-3-2: 2006+ A1:2009+ A2:2009  
EN 61000-3-3: 2008  
EN 61547: 2009

Test Result : Pass

Conclusion : The submitted samples complied with the above EMC standards.

Remark : None.

\*\*\*\*\*End of Page\*\*\*\*\*

***Prepared and Checked By:***

***Approved By:***

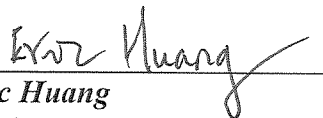
  
***Eric Huang***  
***Engineer***  
***Intertek Guangzhou***

  
***Carrie Chen*** ***Signature***  
***Technical Supervisor***  
***Intertek Guangzhou***  
***29 March 2013*** ***Date***

This report is for the exclusive use of Intertek's Client and is provided pursuant to the agreement between Intertek and its Client. Intertek's responsibility and liability are limited to the terms and conditions of the agreement. Intertek assumes no liability to any party, other than to the Client in accordance with the agreement, for any loss, expense or damage occasioned by the use of this report. Only the Client is authorized to permit copying or distribution of this report and then only in its entirety. Any use of the Intertek name or one of its marks for the sale or advertisement of the tested material, product or service must first be approved in writing by Intertek. The observations and test results in this report are relevant only to the sample tested. This report by itself does not imply that the material, product, or service is or has ever been under an Intertek certification program. The test report only allows to be revised within three years from its original issued date unless further standard or the requirement was noticed.

Intertek Testing Services Shenzhen Ltd. Guangzhou Branch  
Block E, No.7-2 Guang Dong Software Science Park, Caipin Road, Guangzhou Science City, GETDD Guangzhou, China  
Tel / Fax: 86-20-8213 9688/86-20-3205 7538

## CONTENT

<b>TEST REPORT</b> .....	<b>1</b>
<b>CONTENT</b> .....	<b>2</b>
<b>1 TEST RESULTS SUMMARY</b> .....	<b>4</b>
<b>2 EMC RESULTS CONCLUSION</b> .....	<b>5</b>
<b>3 LABORATORY MEASUREMENTS</b> .....	<b>7</b>
<b>4 EMI TEST</b> .....	<b>8</b>
4.1 EN 55015 CONTINUOUS CONDUCTED DISTURBANCE VOLTAGE TEST .....	8
4.1.1 <i>Used Test Equipment</i> .....	8
4.1.2 <i>Block Diagram of Test Setup</i> .....	8
4.1.3 <i>Test Setup and Procedure</i> .....	8
4.1.4 <i>Test Data</i> .....	9
4.1.5 <i>Emission Curve</i> .....	12
4.1.6 <i>Measurement Uncertainty</i> .....	18
4.2 EN 55015 RADIATED ELECTROMAGNETIC DISTURBANCE (9 kHz-30 MHz).....	18
4.2.1 <i>Used Test Equipment</i> .....	18
4.2.2 <i>Block Diagram of Test Setup</i> .....	18
4.2.3 <i>Test Setup and Procedure</i> .....	18
4.2.4 <i>Test Data</i> .....	19
4.2.5 <i>Test Curve</i> .....	20
4.2.6 <i>Measurement Uncertainty</i> .....	22
4.3 EN 55015 RADIATED ELECTROMAGNETIC DISTURBANCE (30 MHz -300 MHz, CDN METHOD) .....	23
4.3.1 <i>Used Test Equipment</i> .....	23
4.3.2 <i>Block Diagram of Test Setup</i> .....	23
4.3.3 <i>Test Setup and Procedure</i> .....	23
4.3.4 <i>Test Data</i> .....	24
4.3.5 <i>Test Curve</i> .....	25
4.3.6 <i>Measurement uncertainty</i> .....	27
4.4 INSERTION LOSS .....	27
<b>5 HARMONICS OF CURRENT</b> .....	<b>28</b>
5.1 USED TEST EQUIPMENT.....	28
5.2 BLOCK DIAGRAM OF TEST SETUP .....	28
5.3 TEST SETUP AND PROCEDURE .....	28
5.4 TEST DATA.....	29
5.5 MEASUREMENT UNCERTAINTY .....	34
<b>6 FLICKER</b> .....	<b>35</b>
6.1 USED TEST EQUIPMENT.....	35
6.2 BLOCK DIAGRAM OF TEST SETUP .....	35
6.3 TEST SETUP AND PROCEDURE .....	35
6.3.1 <i>Definition</i> .....	35
6.3.2 <i>Test condition</i> .....	35
6.4 TEST DATA.....	36
6.5 MEASUREMENT UNCERTAINTY .....	38
<b>7 EMS TEST</b> .....	<b>39</b>
7.1 EN 61000-4-2(PURSUANT TO EN 61547) ELECTROSTATIC DISCHARGE IMMUNITY .....	39
7.1.1 <i>Used Test Equipment</i> .....	39

7.1.2	Block Diagram of Test Setup.....	40
7.1.3	Test Setup and Procedure .....	40
7.1.4	Test Result.....	42
7.2	EN 61000-4-6(PURSUANT TO EN 61547) INJECTED CURRENT (0.15 MHZ TO 80 MHZ) .....	44
7.2.1	Used Test Equipment .....	44
7.2.2	Block Diagram of Test Setup.....	44
7.2.3	Test Setup and Procedure .....	44
7.2.4	Test Result.....	45
7.3	EN 61000-4-4(PURSUANT TO EN 61547) ELECTRICAL FAST TRANSIENT/BURST .....	45
7.3.1	Used Test Equipment .....	45
7.3.2	Block Diagram of Test Setup.....	45
7.3.3	Test Setup and Procedure .....	46
7.3.4	Test Result.....	46
7.4	EN 61000-4-5(PURSUANT TO EN 61547) SURGE IMMUNITY .....	47
7.4.1	Used Test Equipment .....	47
7.4.2	Block Diagram of Test Setup.....	47
7.4.3	Test Setup and Procedure .....	47
7.4.4	Test Result.....	48
7.5	EN 61000-4-11(PURSUANT TO EN 61547) VOLTAGE DIPS AND INTERRUPTIONS .....	48
7.5.1	Used Test Equipment .....	48
7.5.2	Block Diagram of Test Setup.....	48
7.5.3	Test Setup and Procedure .....	49
7.5.4	Test Result.....	49
7.6	EN 61000-4-3(PURSUANT TO EN 61547) RADIATED ELECTROMAGNETIC FIELD IMMUNITY .....	50
7.6.1	Used Test Equipment .....	50
7.6.2	Block Diagram of Test Setup.....	50
7.6.3	Test Setup and Procedure .....	51
7.6.4	Test Result.....	51
<b>8</b>	<b>APPENDIX I - PHOTOS OF TEST SETUP .....</b>	<b>52</b>
<b>9</b>	<b>APPENDIX II- PHOTOS OF EUT.....</b>	<b>57</b>

1

**TEST RESULTS SUMMARY**

<b>Test Item</b>	<b>Standard</b>	<b>Result</b>
<b>Continuous conducted disturbance voltage</b>	EN 55015: 2006+A1: 2007+A2: 2009	<b>Pass</b>
<b>Radiated electromagnetic disturbance (9 kHz -30 MHz)</b>	EN 55015: 2006+A1: 2007+A2: 2009	<b>Pass</b>
<b>Radiated Electromagnetic Disturbance (30 MHz -300 MHz)</b>	EN 55015: 2006+A1: 2007+A2: 2009	<b>Pass</b>
<b>Insertion loss</b>	EN 55015: 2006+A1: 2007+A2: 2009	<b>N/A</b>
<b>Harmonic of current</b>	EN 61000-3-2: 2006+ A1:2009+ A2:2009	<b>Pass</b>
<b>Flicker</b>	EN 61000-3-3: 2008	<b>Pass</b>
<b>ESD immunity</b>	EN 61547:2009 Reference: EN 61000-4-2: 2009	<b>Pass</b>
<b>Radiated EM filed immunity</b>	EN 61547:2009 Reference: EN 61000-4-3:2006+A1 :2008	<b>Pass</b>
<b>EFT immunity</b>	EN 61547:2009 Reference: EN 61000-4-4:2004	<b>Pass</b>
<b>Surge immunity</b>	EN 61547:2009 Reference: EN 61000-4-5:2006	<b>Pass</b>
<b>Inject current immunity</b>	EN 61547:2009 Reference: EN 61000-4-6:2009	<b>Pass</b>
<b>Power frequency magnetic field immunity</b>	EN 61547:2009 Reference: EN 61000-4-8:1993+A1:2001	<b>N/A</b>
<b>Voltage dips and interruption immunity</b>	EN 61547:2009 Reference: EN 61000-4-11:2004	<b>Pass</b>

Remark: 1. The symbol “N/A” in above table means Not Applicable.

2. When determining the test results, measurement uncertainty of tests has been considered.

## 2 EMC Results Conclusion (with Justification)

RE: EMC Testing Pursuant to EMC Directive 2004/108/EC Performed on the a.c. supplied electronic controlgear for LED,modules (LED driver), Models: See page 2.

We tested the a.c. supplied electronic controlgear for LED,modules (LED driver), Models: See page 2, to determine if they were in compliance with the relevant EN standards as marked on the Test Results Summary. We found that the unit met the requirement of EN 55015, EN 61000-3-2, EN 61000-3-3, EN 61547 (EN 61000-4-2), EN 61547 (EN 61000-4-4), EN 61547 (EN 61000-4-6), EN 61547 (EN 61000-4-5), EN 61547 (EN 61000-4-11), & EN 61547 (EN 61000-4-3) standards when tested as received. The worst case’s test data was presented in this test report.Radiated EM filed immunity were subcontracted.

**Remark:**

Models

ELP036C\*\*\*\*LSD1

The 1st to 4th “\*” indicate the output current of LED driver; can be replaced by “0500” to “1000” and increasing in multiplies of 100. “0500” means 500 mA; “1000” means 1000 mA.

**Electrical Rating**

Input: 220-240 VAC; 50/60 Hz; 0,21 A; Class II; IP 20; SELV;  
 ta 50 °C; tc 80 °C; Independent type; 110 °C thermal protection;  
 Inherently short-circuit proof;  
 Output: Constant current type;  
 MM mark;  
 Suitable for direct mounting on normally flammable surfaces;

**Other parameters:**

No.	Model number	Input			Output		
		Voltage (VAC)	Current (A)	Frequency (Hz)	Constant current (mA)	Normal working voltage (VDC)	No load working voltage (VDC)
1	ELP036C1000LSD1	220-240	0,21	50/60	1000	20-35	45
2	ELP036C0900LSD1	220-240	0,21	50/60	900	22-40	50
3	ELP036C800LSD1	220-240	0,21	50/60	800	25-45	55
4	ELP036C0700LSD1	220-240	0,21	50/60	700	28-50	60
5	ELP036C0600LSD1	220-240	0,21	50/60	600	34-60	70
6	ELP036C0500LSD1	220-240	0,21	50/60	500	40-70	76

All models had the same mechanical structure, output load, PCB layout; the only difference is the parameters for the components used in secondary circuit.

Model ELP036C1000LSD1 was selected to do the full tests Models ELP036C0700LSD1; ELP036C0500LSD1 were selected to do Continuous conducted disturbance voltage, Radiated Electromagnetic Disturbance (30 MHz -300 MHz),Harmonic of current, Flicker.



Report No.: 130105062GZU-001  
Issued:2013-3-29

The production units are required to conform to the initial sample as received when the units are placed on the market.



3

**LABORATORY MEASUREMENTS**

**Configuration Information**

<b>Equipment Under Test (EUT):</b> modules (LED driver)	a.c. supplied electronic controlgear for LED
<b>Model:</b>	ELP036C0500LSD1,ELP036C0700LSD1, ELP036C1000LSD1
<b>Serial No.</b>	Not Labeled
<b>Support Equipment:</b>	N/A
<b>Rated Voltage:</b>	220-240 VAC; 50/60 Hz
<b>Condition of Environment:</b>	Temperature : 15~25°C Relative Humidity: 35~60% Atmosphere Pressure 86~106kPa

**Notes:**

1. The EMI measurements had been made in the operating mode produced the largest emission in the frequency band being investigated consistent with normal applications. An attempt had been made to maximize the emission by varying the configuration of the EUT.
2. The EMS measurements had been made in the frequency bands being investigated, with the EUT in the most susceptible operating mode consistent with normal applications. The configuration of the test sample had been varied to achieve maximum susceptibility.

## 4 EMI TEST

### 4.1 EN 55015 Continuous Conducted Disturbance Voltage Test

**Test Result: Pass**

#### 4.1.1 Used Test Equipment

Equipment No.	Equipment	Model	Manufacturer
EM080-05	EMI receiver	ESCS30	R&S
EM006-05	LISN	ENV216	R&S
EM004-04	EMC shield Room	8m×3m×3m	Zhongyu

#### 4.1.2 Block Diagram of Test Setup

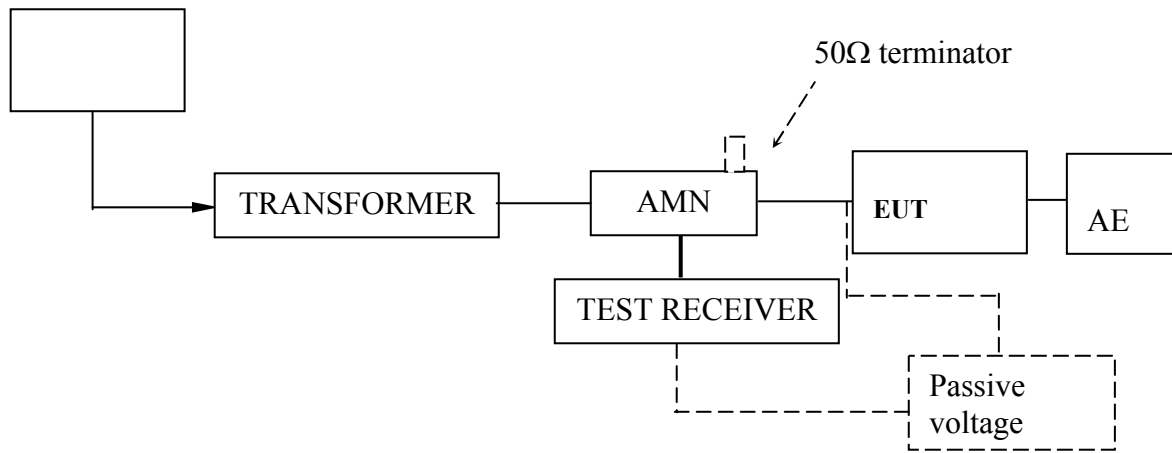

#### 4.1.3 Test Setup and Procedure

The EUT was set to achieve the maximum emission level. The mains terminal disturbance voltage was measured with the EUT in a shielded room. The EUT was connected to AC power source through an Artificial Mains Network which provide a 50Ω linear impedance. Artificial hand is used if appropriate (for handheld apparatus). The load/control terminal disturbance voltage was measured with passive voltage probe if appropriate.

The EUT was placed on a 0.4m high non-metallic table above a metallic plane, and 0.4m from wall of shielded room which is considered as Ground Reference Plane (GRP) (For floor standing EUT, was placed on a 0.1m high non-metallic supported on GRP) The EUT keeps a distance of at least 0.8m from any other of the metallic surface. The Artificial Mains Network is situated at a distance of 0.8m from the EUT.

During the test, mains lead of EUT excess 0.8m was folded back and forth parallel to the lead so as to form a horizontal bundle with a length between 0.3m and 0.4m.

The bandwidth of test receiver was set at 200Hz in the frequency range from 9kHz to 150kHz, and 9kHz in the frequency range from 150kHz to 30MHz.



4.1.4 Test Data

At main terminal: Pass

Model:EIP036C0500LSD1

Tested Wire: Live

Operation Mode:EUI ON

EDIT PEAK LIST (Final Measurement Results)				
Trace1:	CE1511QP			
Trace2:	CE1511AV			
Trace3:	---			
TRACE	FREQUENCY	LEVEL dBμV		DELTA LIMIT dB
2 Average	12.84 kHz	66.27 L1		
2 Average	25.56 kHz	41.26 L1		
2 Average	67.24 kHz	54.56 L1		
2 Average	134.28 kHz	34.86 L1		
1 Quasi Peak	154 kHz	45.83 L1		-19.94
1 Quasi Peak	406 kHz	41.32 L1		-16.40
2 Average	406 kHz	30.59 L1		-17.13
2 Average	942 kHz	28.15 L1		-17.84
1 Quasi Peak	1.006 MHz	42.49 L1		-13.50
1 Quasi Peak	2.414 MHz	43.77 L1		-12.22
2 Average	2.614 MHz	30.61 L1		-15.38
2 Average	3.218 MHz	31.83 L1		-14.16
1 Quasi Peak	3.486 MHz	45.74 L1		-10.25
1 Quasi Peak	6.918 MHz	36.91 L1		-23.08
1 Quasi Peak	25.37 MHz	33.63 L1		-26.36

Tested Wire: Neutral

Operation Mode: EUI ON

EDIT PEAK LIST (Final Measurement Results)				
Trace1:	CE1511QP			
Trace2:	CE1511AV			
Trace3:	---			
TRACE	FREQUENCY	LEVEL dBμV		DELTA LIMIT dB
2 Average	12.84 kHz	51.63 L1		
2 Average	25.56 kHz	44.40 L1		
2 Average	67.32 kHz	55.08 L1		
2 Average	134.36 kHz	35.24 L1		
1 Quasi Peak	154 kHz	47.90 L1		-17.87
1 Quasi Peak	406 kHz	43.91 L1		-13.81
2 Average	406 kHz	33.00 L1		-14.72
2 Average	942 kHz	31.49 L1		-14.50
1 Quasi Peak	1.006 MHz	44.52 L1		-11.47
1 Quasi Peak	2.618 MHz	45.98 L1		-10.01
2 Average	2.618 MHz	33.00 L1		-12.99
2 Average	2.886 MHz	33.32 L1		-12.67
1 Quasi Peak	3.422 MHz	46.19 L1		-9.80
1 Quasi Peak	13.154 MHz	37.58 L1		-22.41
1 Quasi Peak	25.354 MHz	38.74 L1		-21.25
2 Average	25.422 MHz	29.20 L1		-20.79



Report No.: 130105062GZU-001  
 Issued:2013-3-29

Model:EIP036C0700LSD1

Tested Wire: Live

Operation Mode: EUI ON

EDIT PEAK LIST (Final Measurement Results)				
Trace1:	CE1511QP			
Trace2:	CE1511AV			
Trace3:	---			
TRACE	FREQUENCY	LEVEL dBµV		DELTA LIMIT dB
2 Average	12.84 kHz	58.90 L1		
2 Average	25.56 kHz	47.92 L1		
2 Average	73.16 kHz	54.27 L1		
2 Average	150 kHz	41.62 L1		-14.37
1 Quasi Peak	158 kHz	48.88 L1		-16.68
2 Average	370 kHz	36.38 L1		-12.11
1 Quasi Peak	494 kHz	43.54 L1		-12.55
2 Average	1.098 MHz	34.55 L1		-11.44
1 Quasi Peak	1.102 MHz	47.35 L1		-8.64
1 Quasi Peak	2.338 MHz	47.95 L1		-8.04
2 Average	2.338 MHz	34.20 L1		-11.79
1 Quasi Peak	3.07 MHz	48.00 L1		-7.99
2 Average	3.07 MHz	33.46 L1		-12.53
1 Quasi Peak	10.238 MHz	41.21 L1		-18.78
1 Quasi Peak	27.882 MHz	37.97 L1		-22.02

Tested Wire: Neutral

Operation Mode: EUI ON

EDIT PEAK LIST (Final Measurement Results)				
Trace1:	CE1511QP			
Trace2:	CE1511AV			
Trace3:	---			
TRACE	FREQUENCY	LEVEL dBµV		DELTA LIMIT dB
2 Average	73.4 kHz	54.57 L1		
2 Average	150 kHz	41.52 L1		-14.47
1 Quasi Peak	158 kHz	48.38 L1		-17.18
2 Average	294 kHz	35.97 L1		-14.43
1 Quasi Peak	310 kHz	46.45 L1		-13.51
1 Quasi Peak	366 kHz	47.53 L1		-11.06
2 Average	366 kHz	36.81 L1		-11.77
1 Quasi Peak	586 kHz	46.15 L1		-9.84
2 Average	586 kHz	34.62 L1		-11.37
2 Average	878 kHz	34.80 L1		-11.19
1 Quasi Peak	1.39 MHz	48.01 L1		-7.98
2 Average	1.61 MHz	35.37 L1		-10.62
1 Quasi Peak	2.122 MHz	48.67 L1		-7.32
2 Average	2.634 MHz	34.89 L1		-11.10
1 Quasi Peak	2.85 MHz	49.76 L1		-6.24
1 Quasi Peak	4.018 MHz	43.06 L1		-12.93
1 Quasi Peak	6.73 MHz	37.65 L1		-22.34
1 Quasi Peak	26.678 MHz	38.43 L1		-21.56



Report No.: 130105062GZU-001  
Issued:2013-3-29

**Model:EIP036C1000LSD1**

**Tested Wire: Live**

**Operation Mode: EUI ON**

EDIT PEAK LIST (Final Measurement Results)				
Trace1:	CE1511QP			
Trace2:	CE1511AV			
Trace3:	---			
TRACE	FREQUENCY	LEVEL dB $\mu$ V		DELTA LIMIT dB
1 Quasi Peak	56.12 kHz	64.33 L1		-24.61
1 Quasi Peak	222 kHz	42.73 L1		-20.00
2 Average	506 kHz	32.89 L1		-13.10
1 Quasi Peak	510 kHz	44.33 L1		-11.66
1 Quasi Peak	958 kHz	46.03 L1		-9.96
2 Average	958 kHz	33.56 L1		-12.43
1 Quasi Peak	2.47 MHz	48.20 L1		-7.79
2 Average	2.474 MHz	35.54 L1		-10.45
2 Average	2.642 MHz	35.60 L1		-10.39
1 Quasi Peak	2.862 MHz	47.72 L1		-8.27
1 Quasi Peak	22.01 MHz	36.66 L1		-23.33

**Tested Wire: Neutral**

**Operation Mode: EUI ON**

EDIT PEAK LIST (Final Measurement Results)				
Trace1:	CE1511QP			
Trace2:	CE1511AV			
Trace3:	---			
TRACE	FREQUENCY	LEVEL dB $\mu$ V		DELTA LIMIT dB
1 Quasi Peak	56.28 kHz	64.08 L1		-24.83
1 Quasi Peak	222 kHz	45.07 L1		-17.67
2 Average	506 kHz	34.80 L1		-11.19
1 Quasi Peak	510 kHz	45.86 L1		-10.14
1 Quasi Peak	954 kHz	47.42 L1		-8.57
2 Average	954 kHz	34.36 L1		-11.63
1 Quasi Peak	2.466 MHz	48.71 L1		-7.28
2 Average	2.47 MHz	34.44 L1		-11.55
2 Average	2.638 MHz	34.85 L1		-11.14
1 Quasi Peak	2.69 MHz	48.18 L1		-7.81
1 Quasi Peak	6.378 MHz	36.50 L1		-23.49

**At load/control terminal: Not Applicable**

**4.1.5 Emission Curve**  
**At mains terminal:**  
**Model:EIP036C0500LSD1**  
**Tested Wire: Live**

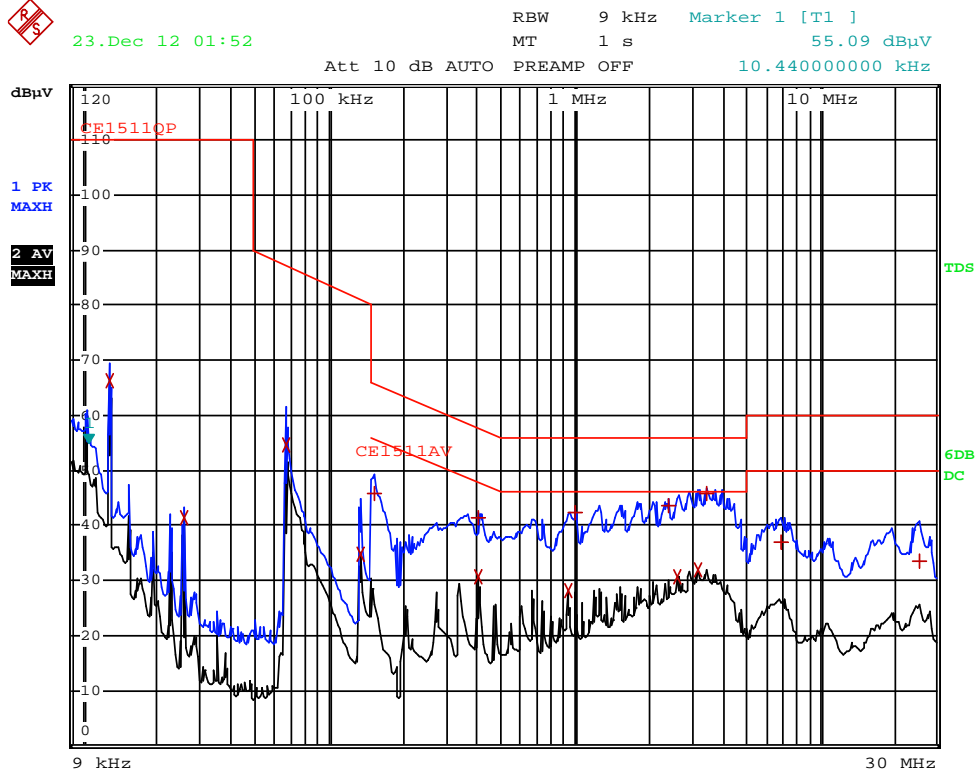



### Tested Wire: Neutral

 23.Dec 12 01:45 RBW 9 kHz Marker 1 [T1 ]  
MT 1 s 60.27 dBuV  
Att 10 dB AUTO PREAMP OFF 10.44000000 kHz

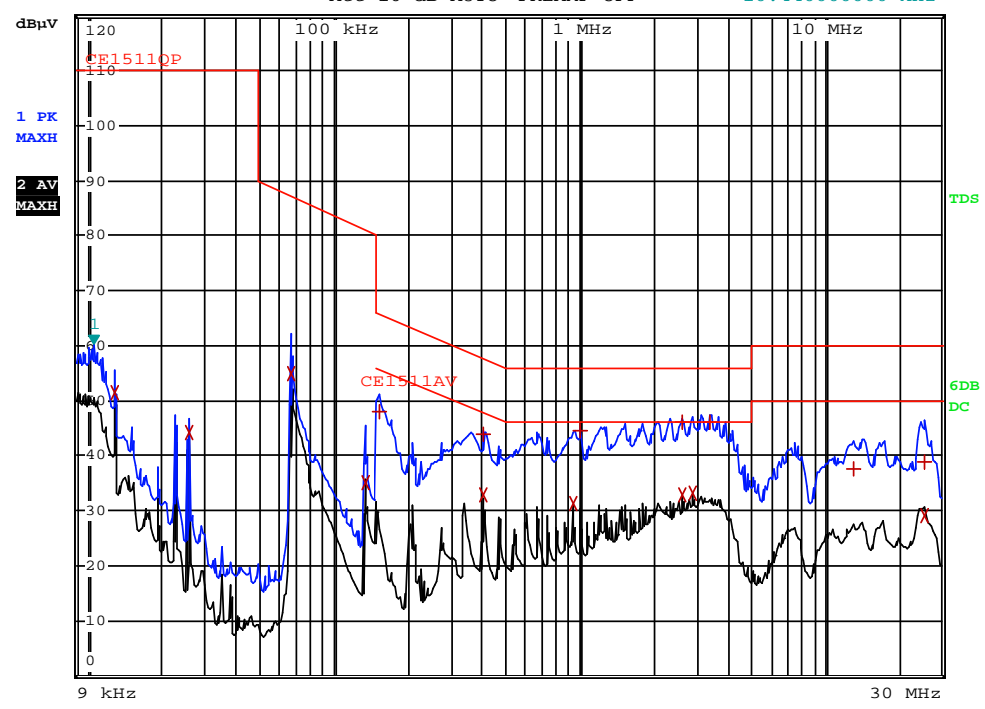



**Model:EIP036C0700LSD1**  
**Tested Wire: Live**

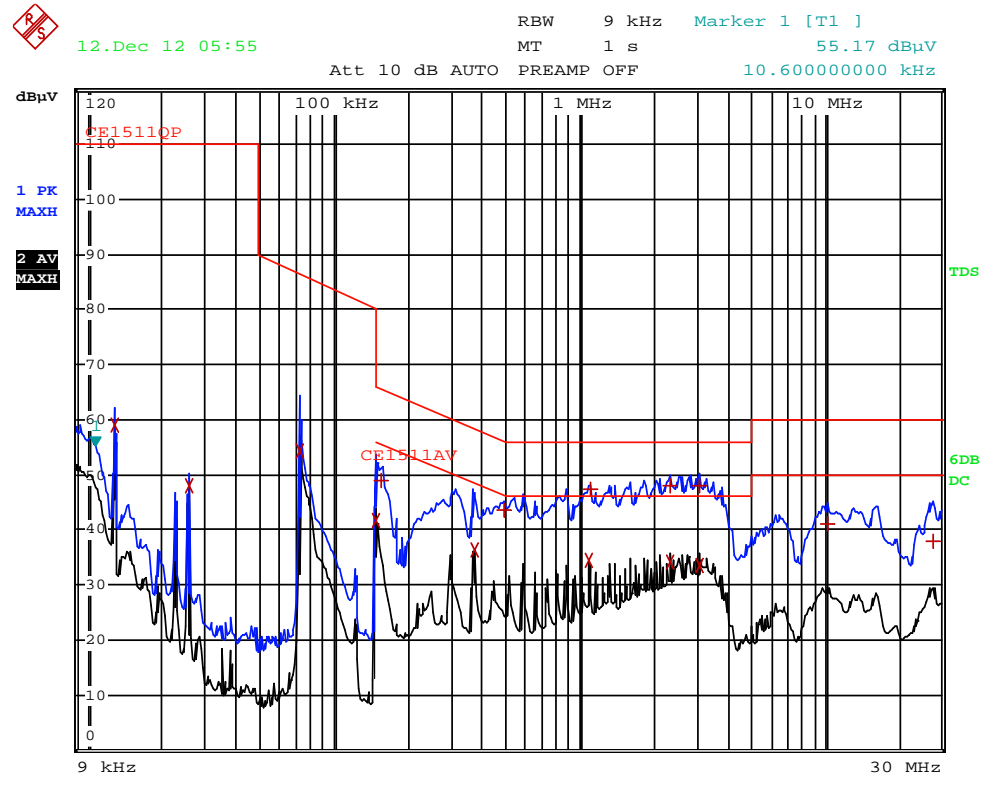





### Tested Wire: Neutral

12.Dec 12 06:03 RBW 9 kHz Marker 1 [T1 ]  
MT 1 s 54.98 dBuV  
Att 10 dB AUTO PREAMP OFF 11.08000000 kHz

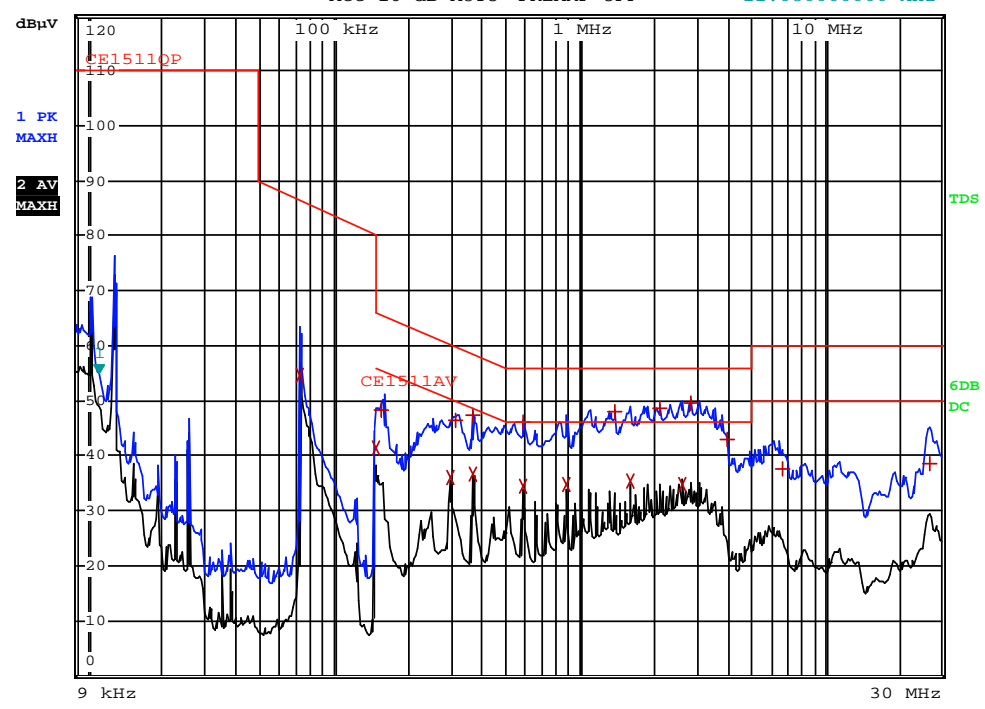



Report No.: 130105062GZU-001  
Issued:2013-3-29

Model:EIP036C1000LSD1  
Tested Wire: Live

27.Dec 12 08:12 RBW 9 kHz Marker 1 [T1 ]  
MT 1 s 55.97 dB $\mu$ V  
Att 10 dB AUTO PREAMP OFF 10.28000000 kHz

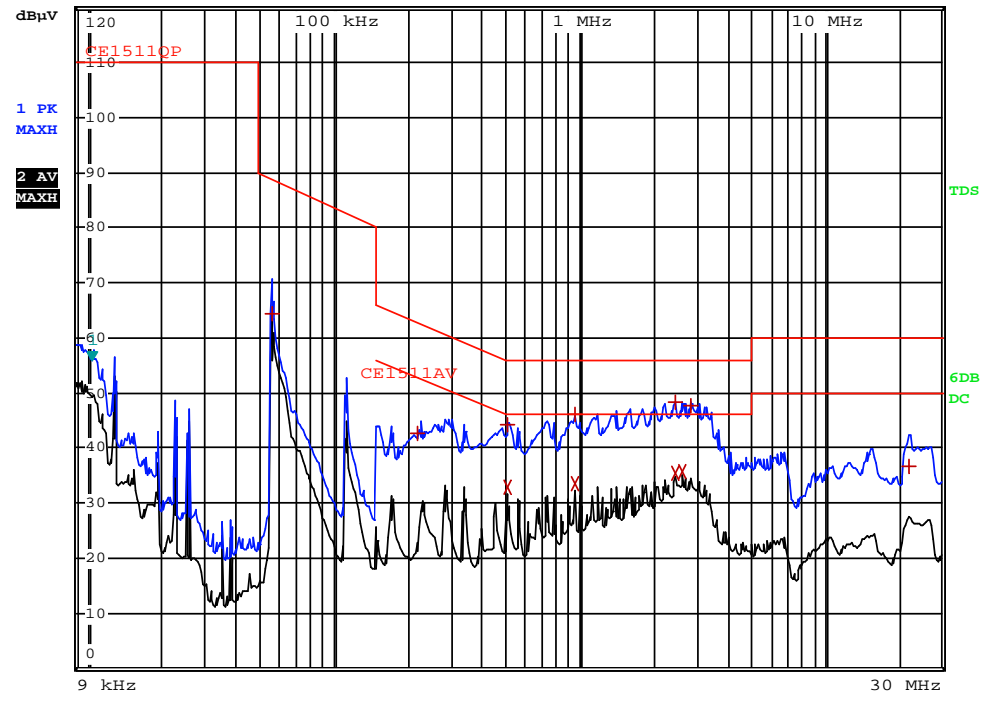



### Tested Wire: Neutral

RBW 9 kHz Marker 1 [T1 ]  
MT 1 s 56.69 dBuV  
Att 10 dB AUTO PREAMP OFF 10.28000000 kHz

27.Dec 12 08:20

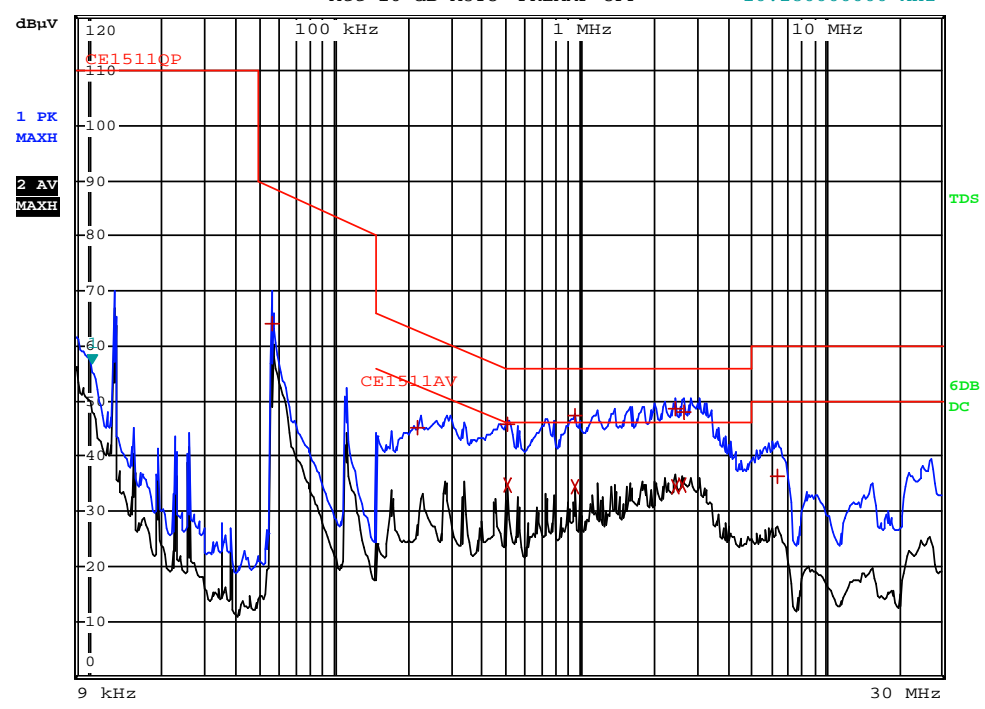

**At load/control terminal:**

**Not Applicable.**

**4.1.6 Measurement Uncertainty**

The measurement uncertainty describes the overall uncertainty of the given measured value during the operation of the EUT.

Measurement uncertainty is calculated in accordance with CISPR 16-4-2: 2003.

Measurement uncertainty of mains terminal disturbance voltage in CISPR band A: 1.6 dB.

Measurement uncertainty of mains terminal disturbance voltage in CISPR band B: 2.3 dB.

The measurement uncertainty is given with a confidence of 95%, k=2.

**4.2 EN 55015 Radiated Electromagnetic Disturbance (9 kHz-30 MHz)**

**Test Result: Pass**

**4.2.1 Used Test Equipment**

Equipment No.	Equipment	Model	Manufacturer
EM080-04	EMI receiver	ESCS30	R&S
EM061-04	Triple Loop Antenna	HXYZ9170	SCHWARZBECK
EM004-03	EMC shield Room	8m×4m×3m	Zhongyu

**4.2.2 Block Diagram of Test Setup**

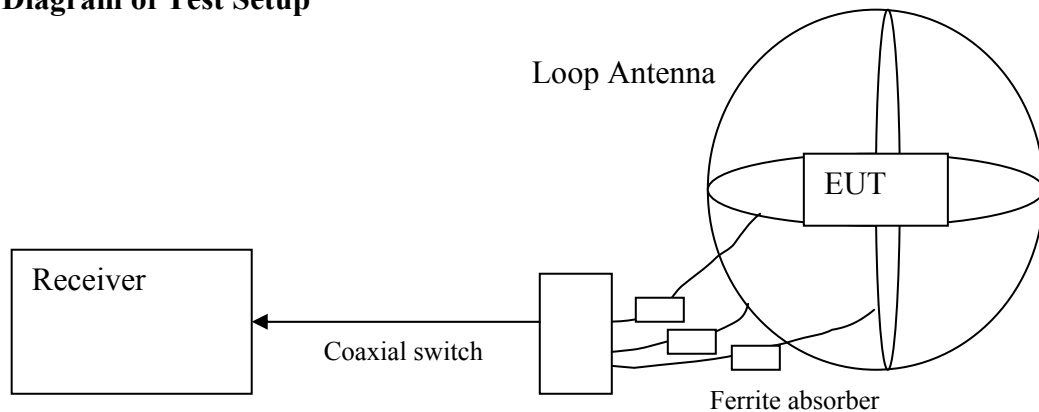

**4.2.3 Test Setup and Procedure**

The EUT is placed in the centre of the loop antenna system(LAS). The current induced by the magnetic field from the EUT into each of the three large loop antennas of the LAS is measured by connecting the current probe of the large loop antenna to a measuring receiver. During the measurements the EUT remains in a fixed position.

The currents in the three large loop antenna, origination from the three mutually orthogonal magnetic field components, are measured in sequence. Each current level measured shall comply with the emission limit, expressed in dBμA, as specified in table of EN 55015.

The distance between the outer perimeter of the LAS and nearby objects, such as floor and walls, shall be at least 0.5m.

To avoid unwanted capacitive coupling between the EUT and the LAS, the maximum dimensions of the EUT shall allow a distance of at least 0.2m between the EUT and the standardized 2m large loop antenna of the LAS.

The position of the mains lead shall be optimized for maximum current induction. In general, this position will not be critical when the EUT complies with the conducted emission limit.

#### 4.2.4 Test Data

<b>Frequency [MHz]</b>	<b>X axis [dB(μA)]</b>	<b>Y axis [dB(μA)]</b>	<b>Z axis [dB(μA)]</b>	<b>Limit [dB(μA)]</b>
0.009	<78	<78	<78	88.0
0.050	<78	<78	<78	88.0
0.100	<64	<64	<64	74.0
0.160	<47	<47	<47	57.2
0.240	<40	<40	<40	52.4
0.550	<30	<30	<30	42.5
1.000	<25	<25	<25	35.4
1.400	<20	<20	<20	31.4
2.000	<17	<17	<17	27.1
3.500	<12	<12	<12	22.0
6.000	<12	<12	<12	22.0
10.000	<12	<12	<12	22.0
22.000	<12	<12	<12	22.0
30.000	<12	<12	<12	22.0

### 4.2.5 Test Curve X axis

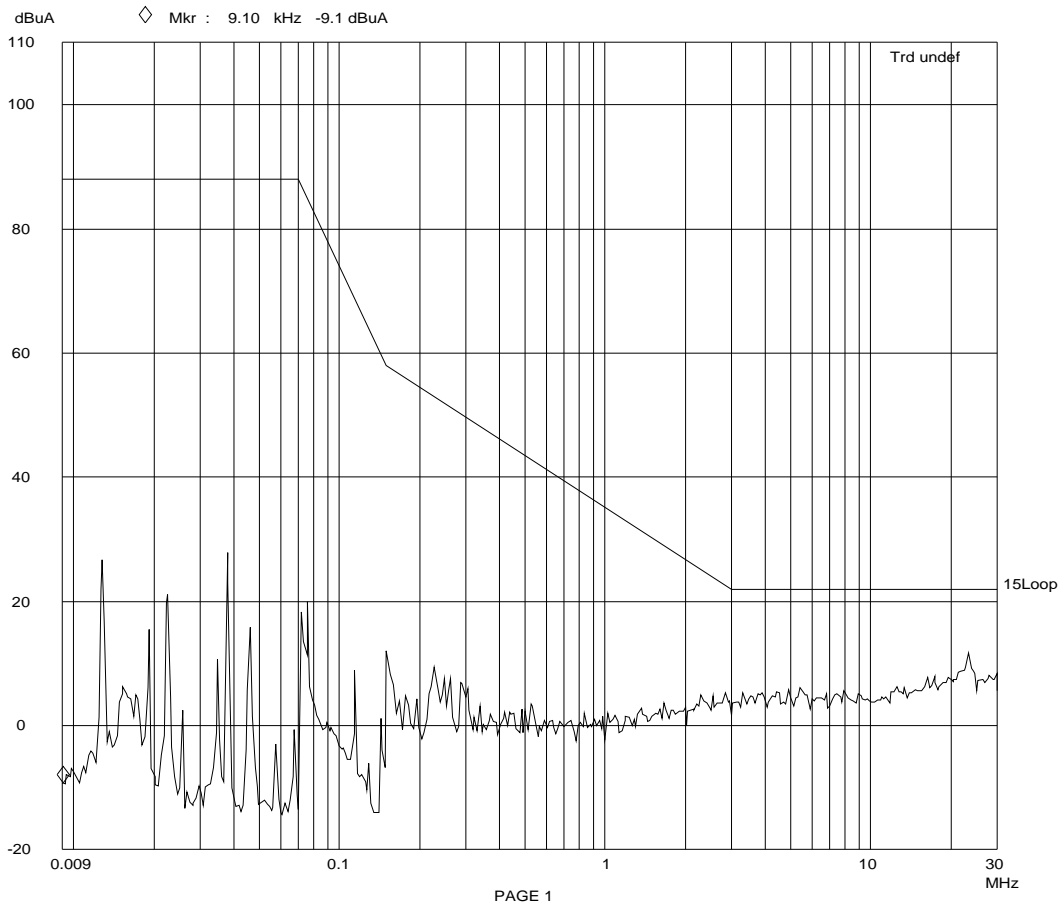

Y axis

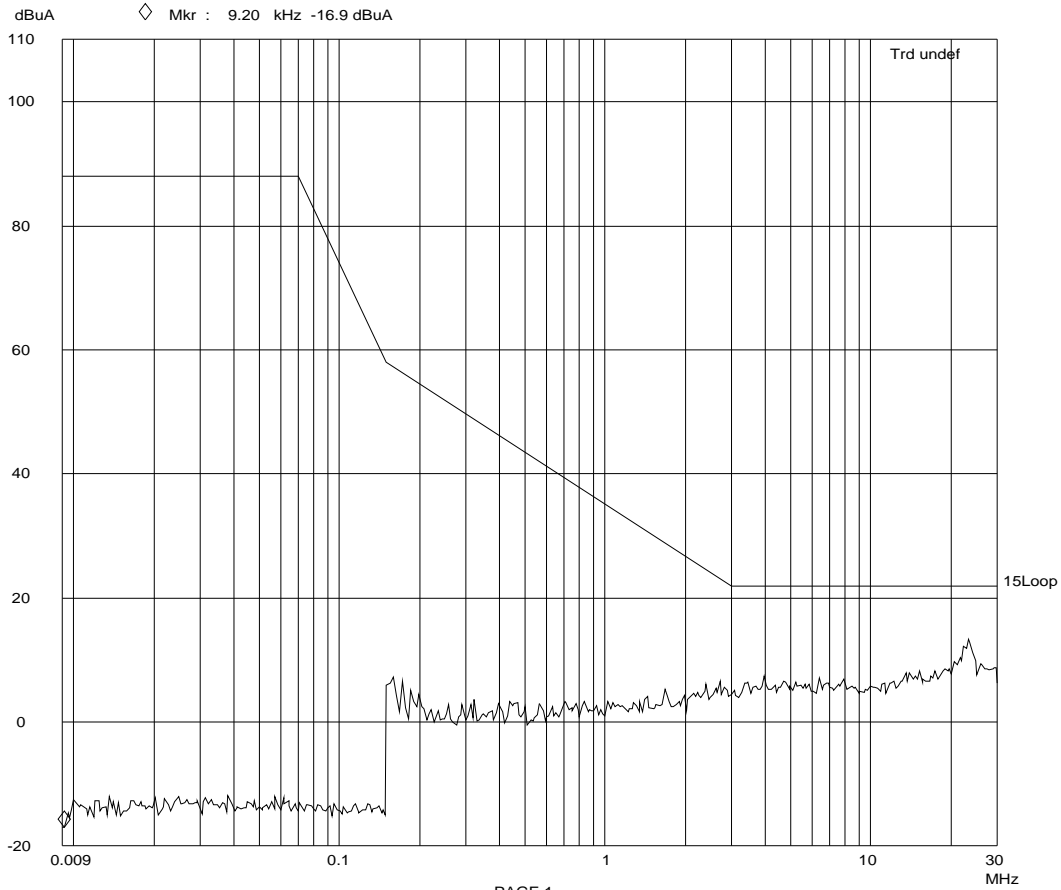

Z axis

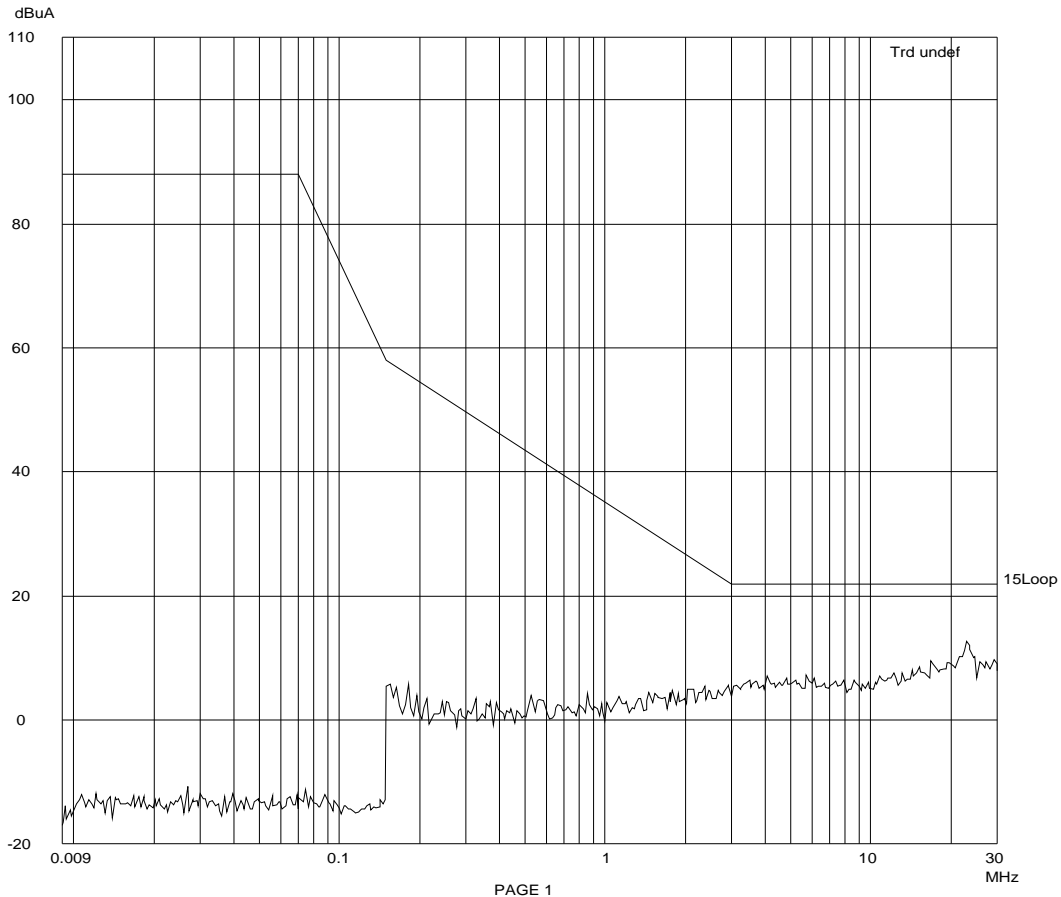

**4.2.6 Measurement Uncertainty**

The measurement uncertainty for induction current is under consideration according to CISPR 16-4-2:2003.



**4.3 EN 55015 Radiated Electromagnetic Disturbance (30 MHz -300 MHz, CDN method)  
 Test Result: Pass**

**4.3.1 Used Test Equipment**

Equip. No.	Equipment	Model	Manufacturer
EM004-04	EMC shield Room	8m×3m×3m	Zhongyu
EM080-05	EMI receiver	ESCI	R&S
EM003-02	Coupling & Decoupling Network	CDN M2 16	TESEQ
EM003-01-05	Attenuator	6dB	drhubert

**4.3.2 Block Diagram of Test Setup**

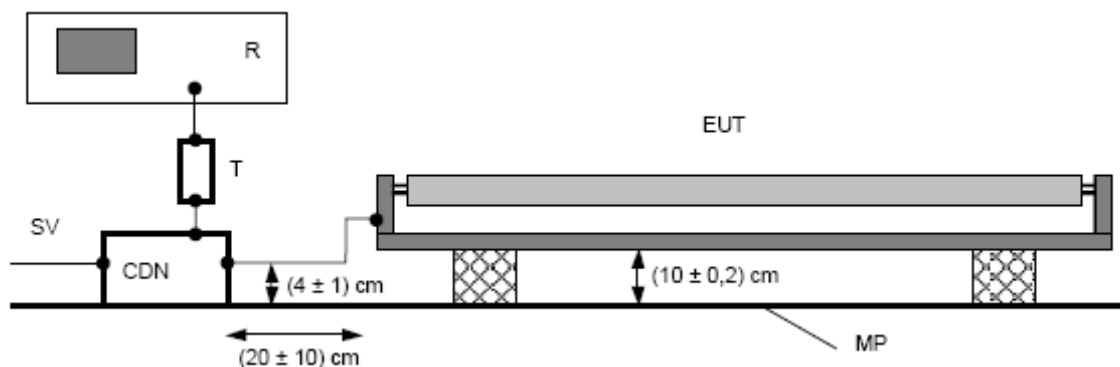

**4.3.3 Test Setup and Procedure**

The EUT shall be placed on a non-conducting table with a height of  $(10 \pm 0.2)$  cm.  
 The EUT is connected to CDN with a length of  $(20 \pm 10)$  cm and the distance of the cable to the metal plate should be  $(4 \pm 1)$  cm.  
 The RF output of the CDN is connected to EMI receiver via a 6 dB, 50Ω attenuator.  
 The distance from any conductive parts shall be more than 40 cm.

Prior to a measurement, the lamps shall be operated until stabilization has been reached. 5min for incandescent lamps, 15min for fluorescent lamp, 30min for other discharge lamp.

The EUT should be powered on before the coaxial cable is connected to receiver every time. And the coaxial cable should be removed from receiver before stopping EUT.



4.3.4 Test Data

**Model:EIP036C0500LSD1**

EDIT PEAK LIST (Final Measurement Results)				
Trace1:	15CDN			
Trace2:	---			
Trace3:	---			
TRACE	FREQUENCY	LEVEL dBμV		DELTA LIMIT dB
1 Quasi Peak	34.2 MHz	51.49 L1		-11.41
1 Quasi Peak	51.16 MHz	47.94 L1		-11.61
1 Quasi Peak	73.52 MHz	44.88 L1		-11.67
1 Quasi Peak	226.32 MHz	42.17 L1		-11.82
1 Quasi Peak	98.68 MHz	41.31 L1		-12.79
1 Quasi Peak	223.64 MHz	40.98 L1		-13.01
1 Quasi Peak	43.68 MHz	47.45 L1		-13.42
1 Quasi Peak	55.36 MHz	44.18 L1		-14.73
1 Quasi Peak	109.56 MHz	39.14 L1		-14.85
1 Quasi Peak	39.32 MHz	46.87 L1		-14.88
1 Quasi Peak	138.52 MHz	37.96 L1		-16.04
1 Quasi Peak	68.2 MHz	40.89 L1		-16.28
1 Quasi Peak	170.56 MHz	36.28 L1		-17.72
1 Quasi Peak	94.48 MHz	36.48 L1		-17.98
1 Quasi Peak	161.92 MHz	34.33 L1		-19.67

**Model:EIP036C0700LSD1**

EDIT PEAK LIST (Final Measurement Results)				
Trace1:	15CDN			
Trace2:	---			
Trace3:	---			
TRACE	FREQUENCY	LEVEL dBμV		DELTA LIMIT dB
1 Quasi Peak	31.92 MHz	54.86 L1		-8.62
1 Quasi Peak	101.8 MHz	41.14 L1		-12.85
1 Quasi Peak	131.32 MHz	40.88 L1		-13.11
1 Quasi Peak	118.8 MHz	40.57 L1		-13.43
1 Quasi Peak	64.2 MHz	43.95 L1		-13.73
1 Quasi Peak	61.48 MHz	44.18 L1		-13.85
1 Quasi Peak	93.56 MHz	39.58 L1		-14.96
1 Quasi Peak	44.12 MHz	44.93 L1		-15.86
1 Quasi Peak	162.56 MHz	37.72 L1		-16.27
1 Quasi Peak	53.32 MHz	42.67 L1		-16.55
1 Quasi Peak	34.68 MHz	44.82 L1		-17.97
1 Quasi Peak	73.12 MHz	37.71 L1		-18.88
1 Quasi Peak	168.92 MHz	33.56 L1		-20.43
1 Quasi Peak	229.08 MHz	33.17 L1		-20.82
1 Quasi Peak	200.76 MHz	32.99 L1		-21.00



**Model:EIP036C1000LSD1**

EDIT PEAK LIST (Final Measurement Results)				
TRACE		FREQUENCY	LEVEL dBμV	DELTA LIMIT dB
Trace1:	15CDN			
Trace2:	---			
Trace3:	---			
1	Quasi Peak	181.12 MHz	40.32 L1	-13.67
1	Quasi Peak	58.96 MHz	44.60 L1	-13.77
1	Quasi Peak	94.28 MHz	40.41 L1	-14.07
1	Quasi Peak	60.32 MHz	43.82 L1	-14.37
1	Quasi Peak	31.56 MHz	48.76 L1	-14.81
1	Quasi Peak	96.32 MHz	39.35 L1	-14.96
1	Quasi Peak	191.04 MHz	38.22 L1	-15.77
1	Quasi Peak	129.8 MHz	37.77 L1	-16.22
1	Quasi Peak	47.48 MHz	43.79 L1	-16.39

**4.3.5 Test Curve**

**Model:EIP036C0500LSD1**

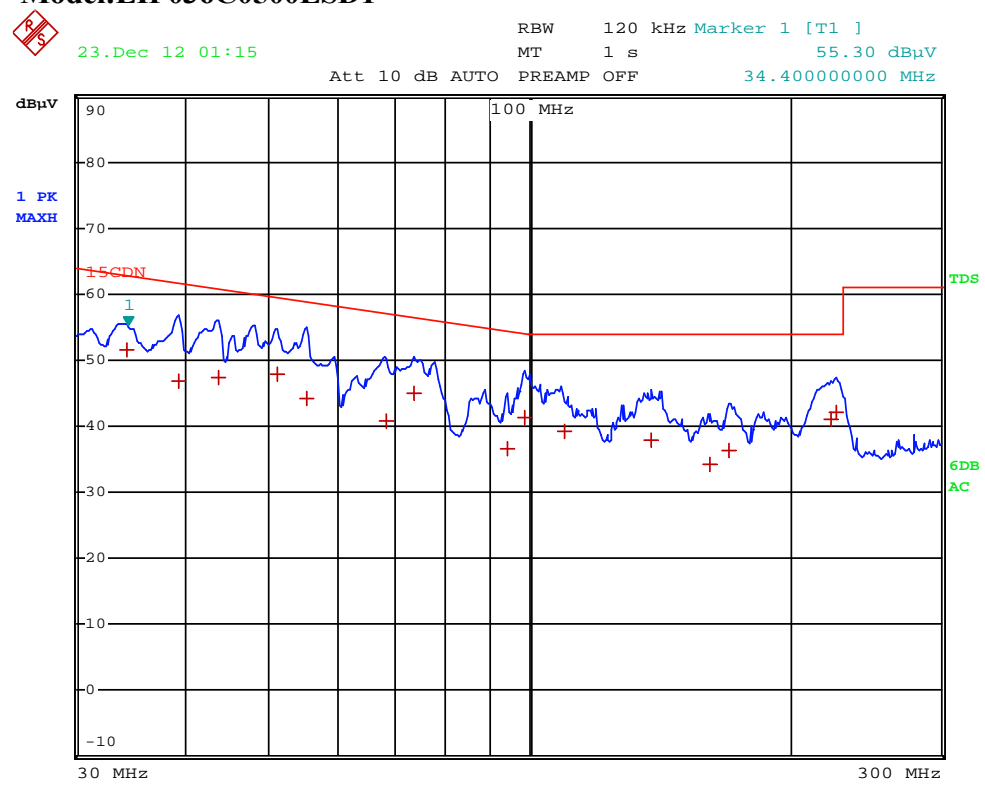



Report No.: 130105062GZU-001  
Issued:2013-3-29

Model:EIP036C0700LSD1

RBW 120 kHz Marker 1 [T1 ]  
MT 1 s 50.88 dBuV  
Att 10 dB AUTO PREAMP OFF 34.40000000 MHz

23.Dec 12 01:07

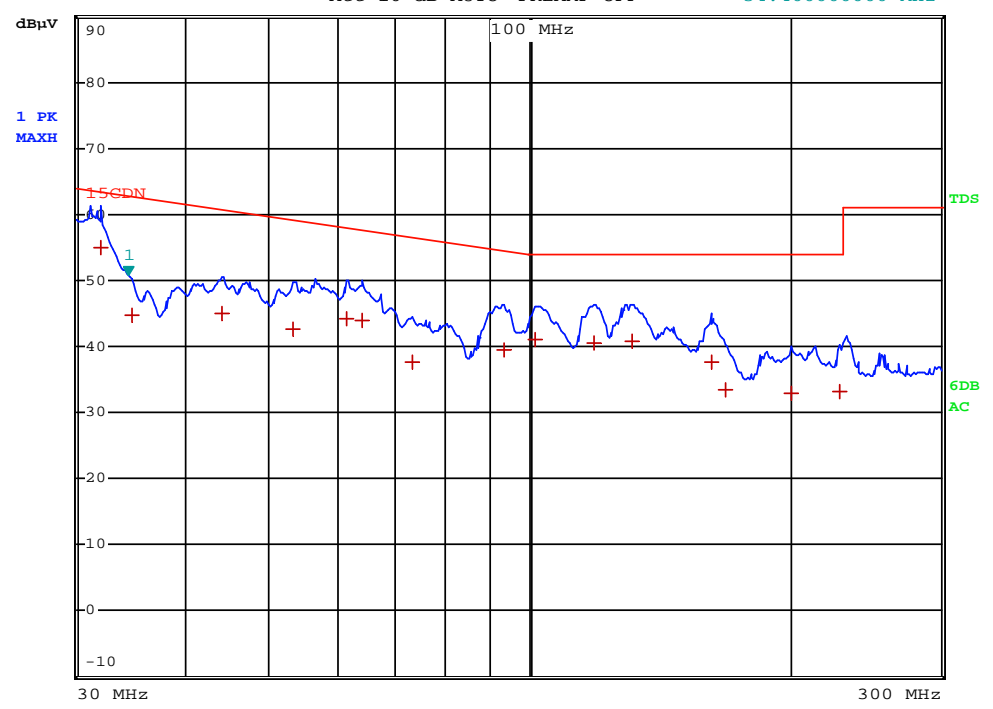

**Model:EIP036C1000LSD1**

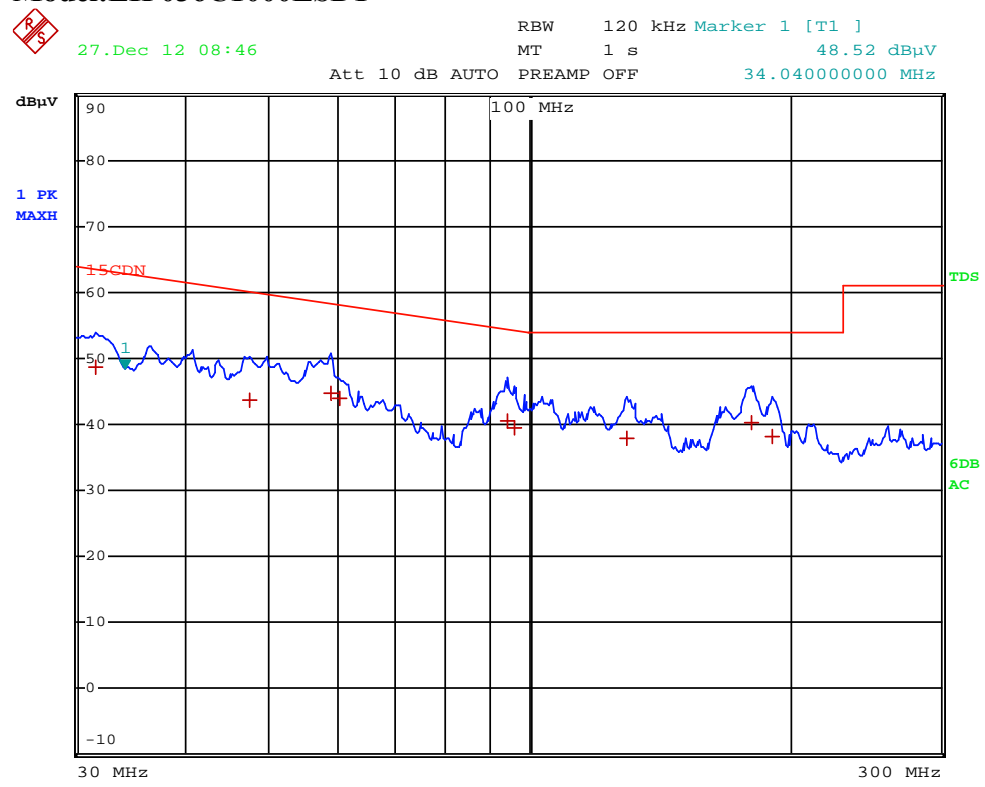

**4.3.6 Measurement uncertainty**

The measurement uncertainty for Radiated Electromagnetic Disturbance t (30 MHz -300 MHz, CDN method) is under consideration according to CISPR 16-4-2:2003.

**4.4 Insertion Loss**

**Test Result: Not Applicable.**  
**Remark: Not required by standard.**

## 5 Harmonics of current

**Test Result: Pass**

### 5.1 Used Test Equipment

Equipment No.	Equipment	Model	Manufacturer
EM001-02	Harmonic & Flicker Test System	5001IX-CTS-400-413	California Instrument

### 5.2 Block Diagram of Test Setup

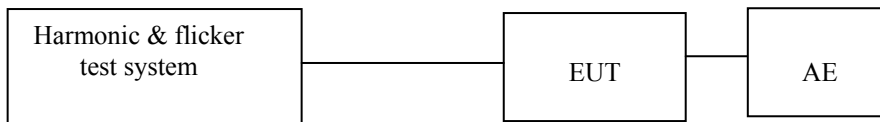

### 5.3 Test Setup and Procedure

Harmonics of the fundamental current were measured up to 40 order harmonics using a digital power meter with an analogue output and frequency analyzer which was integrated in the harmonic & flicker test system. The measurements were carried out under steady conditions.

**5.4 Test Data**

**Model:EIP036C0500LSD1**

**Harmonics – Class-C per Ed. 3.0 (incl. inter-harmonics)**

Current & voltage waveforms

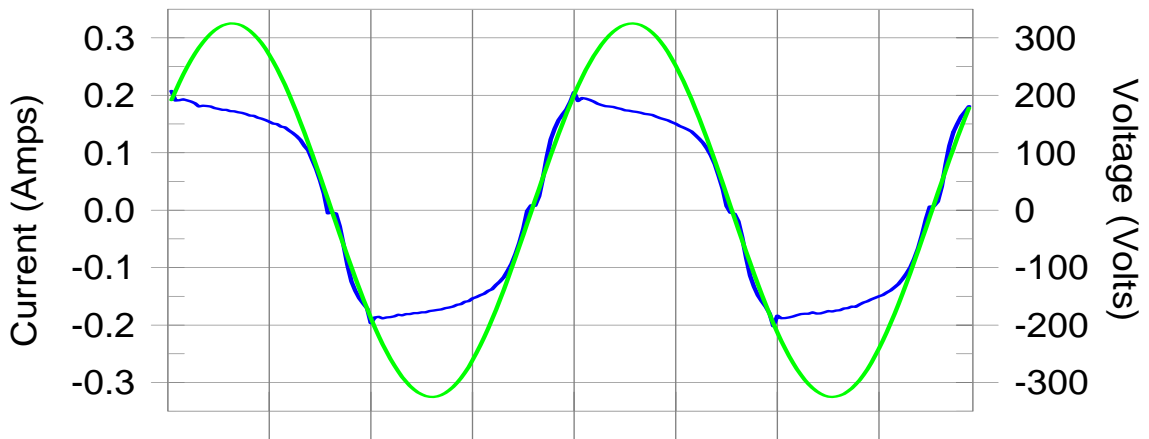

Harmonics and Class C limit line

European Limits

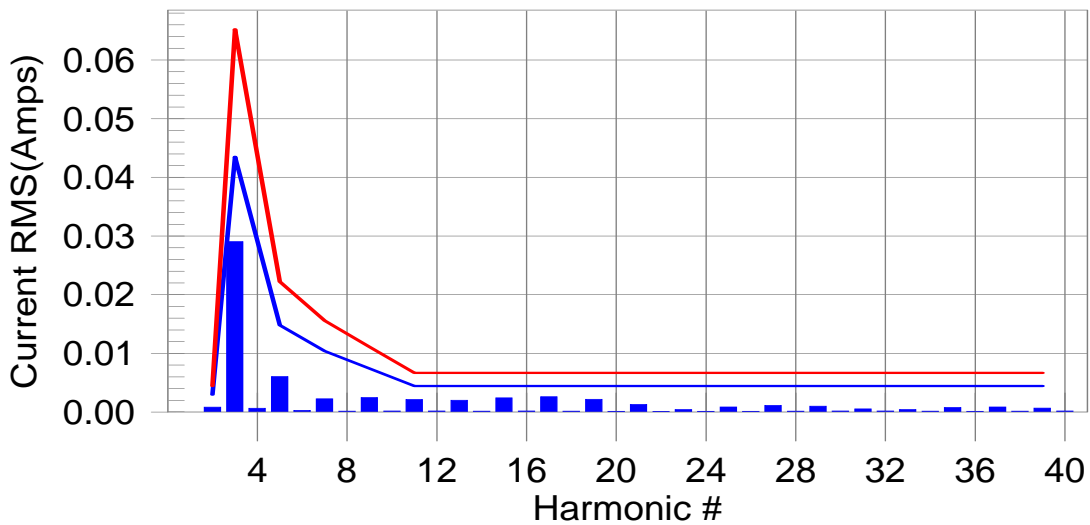

**Test result: Pass Worst harmonics H3-66.76% of 100% limit, H3-46.65% of 150% limit.**



**Current Test Result Summary (Run time)**

Test Result: Pass

Source qualification: Normal

Highest parameter values during test:

V_RMS (Volts):	230.08	Frequency(Hz):	50.00
I_Peak (Amps):	0.214	I_RMS (Amps):	0.151
I_Fund (Amps):	0.148	Crest Factor:	1.428
Power (Watts):	34.0	Power Factor:	0.979

Harm#	Harms(avg)	100%Limit	%of Limit	Harms(max)	150%Limit	%of Limit	Status
2	0.001	0.003	0.0	0.001	0.004	0.00	Pass
3	0.029	0.044	66.8	0.030	0.064	46.65	Pass
4	0.001						
5	0.006	0.015	40.7	0.008	0.022	35.37	Pass
6	0.000						
7	0.002	0.010	0.0	0.003	0.016	0.00	Pass
8	0.000						
9	0.002	0.007	0.0	0.003	0.011	0.00	Pass
10	0.000						
11	0.002	0.004	0.0	0.002	0.007	0.00	Pass
12	0.000						
13	0.002	0.004	0.0	0.002	0.007	0.00	Pass
14	0.000						
15	0.002	0.004	0.0	0.003	0.007	0.00	Pass
16	0.000						
17	0.003	0.004	0.0	0.003	0.007	0.00	Pass
18	0.000						
19	0.002	0.004	0.0	0.002	0.007	0.00	Pass
20	0.000						
21	0.001	0.004	0.0	0.001	0.007	0.00	Pass
22	0.000						
23	0.000	0.004	0.0	0.000	0.007	0.00	Pass
24	0.000						
25	0.001	0.004	0.0	0.001	0.007	0.00	Pass
26	0.000						
27	0.001	0.004	0.0	0.001	0.007	0.00	Pass
28	0.000						
29	0.001	0.004	0.0	0.001	0.007	0.00	Pass
30	0.000						
31	0.001	0.004	0.0	0.001	0.007	0.00	Pass
32	0.000						
33	0.000	0.004	0.0	0.000	0.007	0.00	Pass
34	0.000						
35	0.001	0.004	0.0	0.001	0.007	0.00	Pass
36	0.000						
37	0.001	0.004	0.0	0.001	0.007	0.00	Pass
38	0.000						
39	0.001	0.004	0.0	0.001	0.007	0.00	Pass
40	0.000						



**Model:EIP036C0700LSD1**

**Harmonics – Class-C per Ed. 3.0 (incl. inter-harmonics)**

Current & voltage waveforms

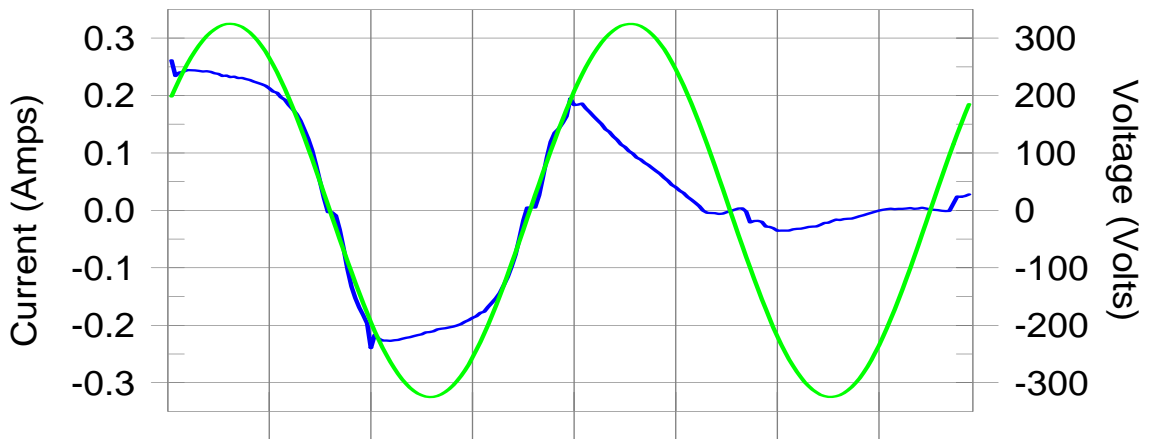

Harmonics and Class C limit line

European Limits

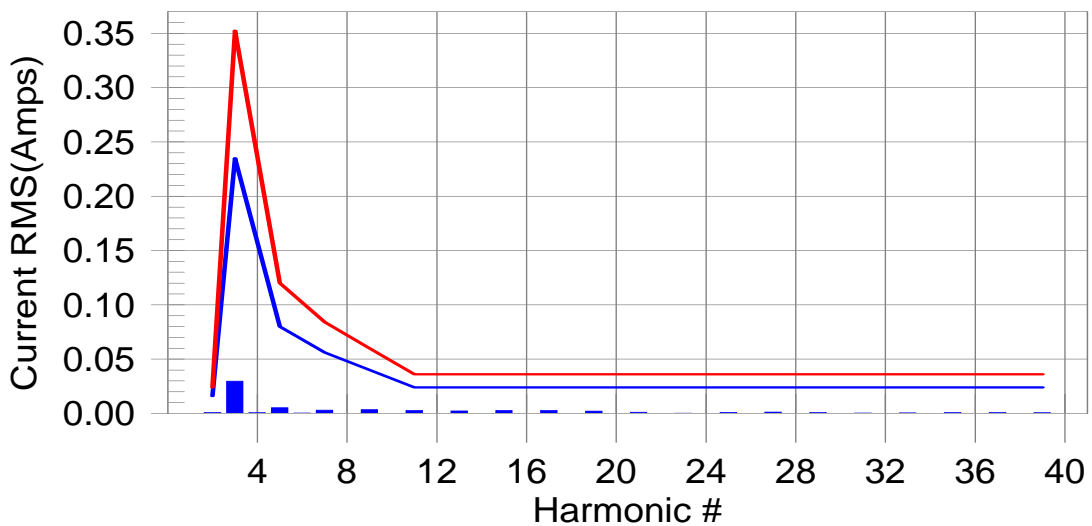

**Test result: Pass Worst harmonics H3-12.68% of 100% limit, H3-8.81% of 150% limit.**



### Current Test Result Summary (Run time)

Test Result: Pass

Source qualification: Normal

Highest parameter values during test:

V_RMS (Volts):	230.07	Frequency(Hz):	50.00
I_Peak (Amps):	0.261	I_RMS (Amps):	0.173
I_Fund (Amps):	0.801	Crest Factor:	2.803
Power (Watts):	39.2	Power Factor:	0.983

Harm#	Harms(avg)	100%Limit	%of Limit	Harms(max)	150%Limit	%of Limit	Status
2	0.001	0.016	0.0	0.002	0.024	0.00	Pass
3	0.030	0.235	12.7	0.031	0.353	8.81	Pass
4	0.001						
5	0.005	0.080	6.6	0.007	0.120	6.02	Pass
6	0.001						
7	0.003	0.056	0.0	0.004	0.084	0.00	Pass
8	0.000						
9	0.004	0.040	0.0	0.004	0.060	0.00	Pass
10	0.000						
11	0.003	0.024	0.0	0.003	0.036	0.00	Pass
12	0.000						
13	0.002	0.024	0.0	0.003	0.036	0.00	Pass
14	0.000						
15	0.003	0.024	0.0	0.003	0.036	0.00	Pass
16	0.000						
17	0.003	0.024	0.0	0.003	0.036	0.00	Pass
18	0.000						
19	0.002	0.024	0.0	0.002	0.036	0.00	Pass
20	0.000						
21	0.001	0.024	0.0	0.001	0.036	0.00	Pass
22	0.000						
23	0.000	0.024	0.0	0.000	0.036	0.00	Pass
24	0.000						
25	0.001	0.024	0.0	0.001	0.036	0.00	Pass
26	0.000						
27	0.001	0.024	0.0	0.001	0.036	0.00	Pass
28	0.000						
29	0.001	0.024	0.0	0.001	0.036	0.00	Pass
30	0.000						
31	0.000	0.024	0.0	0.001	0.036	0.00	Pass
32	0.000						
33	0.001	0.024	0.0	0.001	0.036	0.00	Pass
34	0.000						
35	0.001	0.024	0.0	0.001	0.036	0.00	Pass
36	0.000						
37	0.001	0.024	0.0	0.001	0.036	0.00	Pass
38	0.000						
39	0.001	0.024	0.0	0.001	0.036	0.00	Pass
40	0.000						

**Model:EIP036C1000LSD1**

**Harmonics – Class-C per Ed. 3.0 (incl. inter-harmonics)**

Current & voltage waveforms

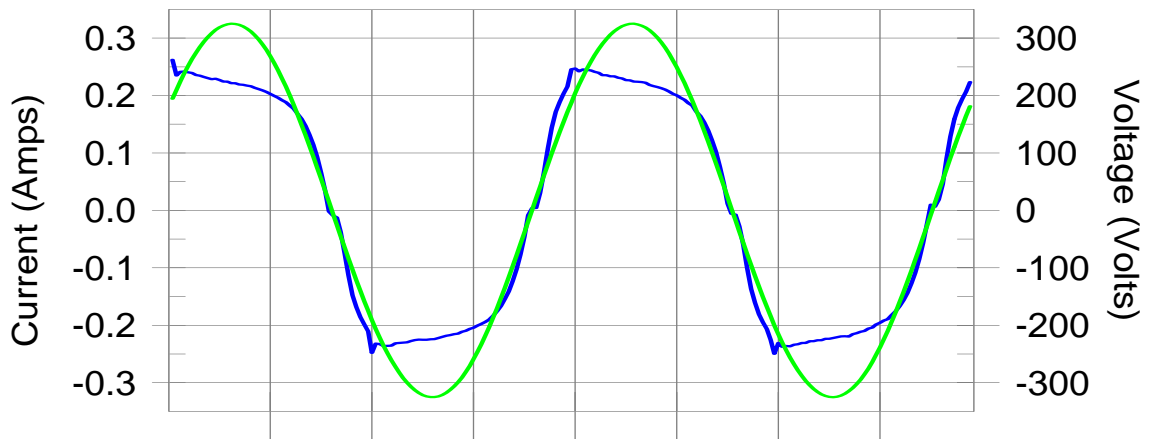

Harmonics and Class C limit line

European Limits

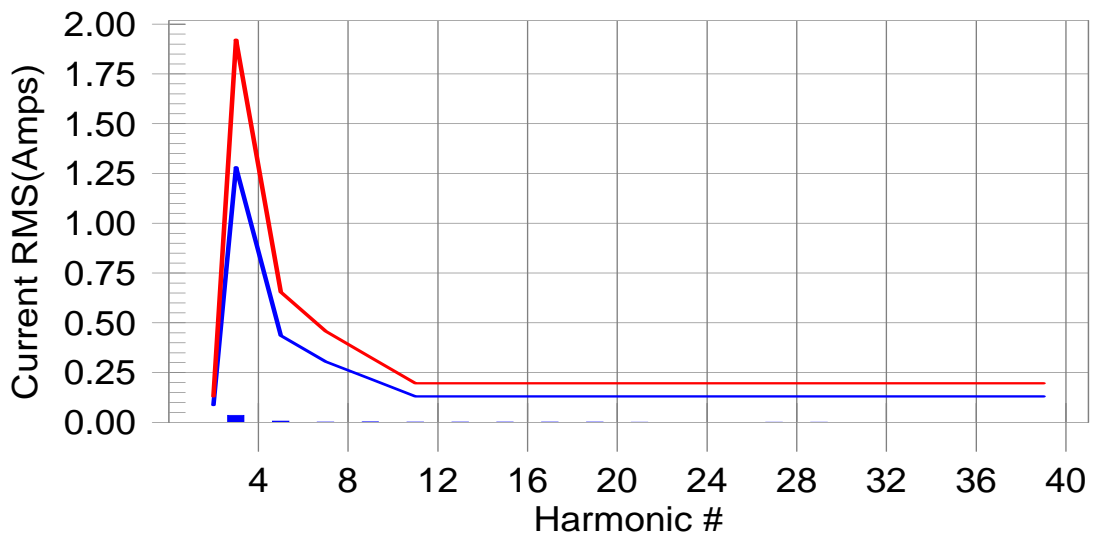

**Test result: Pass Worst harmonics H3-2.77% of 100% limit, H3-1.89% of 150% limit.**

**Current Test Result Summary (Run time)**

Test Result: Pass

Source qualification: Normal

Highest parameter values during test:

V_RMS (Volts):	230.09	Frequency(Hz):	50.00
I_Peak (Amps):	0.264	I_RMS (Amps):	0.192
I_Fund (Amps):	4.363	Crest Factor:	1.386
Power (Watts):	43.4	Power Factor:	0.982

Harm#	Harms(avg)	100%Limit	%of Limit	Harms(max)	150%Limit	%of Limit	Status
2	0.001	0.087	0.0	0.001	0.131	0.00	Pass
3	0.036	1.282	2.8	0.036	1.923	1.89	Pass
4	0.001						
5	0.006	0.436	1.5	0.008	0.654	1.23	Pass
6	0.000						
7	0.003	0.305	0.0	0.003	0.458	0.00	Pass
8	0.000						
9	0.003	0.218	0.0	0.003	0.327	0.00	Pass
10	0.000						
11	0.002	0.131	0.0	0.003	0.196	0.00	Pass
12	0.000						
13	0.002	0.131	0.0	0.002	0.196	0.00	Pass
14	0.000						
15	0.003	0.131	0.0	0.003	0.196	0.00	Pass
16	0.000						
17	0.003	0.131	0.0	0.003	0.196	0.00	Pass
18	0.000						
19	0.002	0.131	0.0	0.002	0.196	0.00	Pass
20	0.000						
21	0.001	0.131	0.0	0.002	0.196	0.00	Pass
22	0.000						
23	0.000	0.131	0.0	0.000	0.196	0.00	Pass
24	0.000						
25	0.001	0.131	0.0	0.001	0.196	0.00	Pass
26	0.000						
27	0.001	0.131	0.0	0.001	0.196	0.00	Pass
28	0.000						
29	0.001	0.131	0.0	0.001	0.196	0.00	Pass
30	0.000						
31	0.001	0.131	0.0	0.001	0.196	0.00	Pass
32	0.000						
33	0.000	0.131	0.0	0.000	0.196	0.00	Pass
34	0.000						
35	0.001	0.131	0.0	0.001	0.196	0.00	Pass
36	0.000						
37	0.001	0.131	0.0	0.001	0.196	0.00	Pass
38	0.000						
39	0.001	0.131	0.0	0.001	0.196	0.00	Pass
40	0.000						

**5.5 Measurement Uncertainty**

The measurement uncertainty for harmonic test is under consideration according to CISPR 16-4-2:2003.

## 6 Flicker

**Test Result: Pass**

### 6.1 Used Test Equipment

Equipment No.	Equipment	Model	Manufacturer
EM001-02	Harmonic & Flicker Test System	5001IX-CTS-400-413	California Instrument

### 6.2 Block Diagram of Test Setup

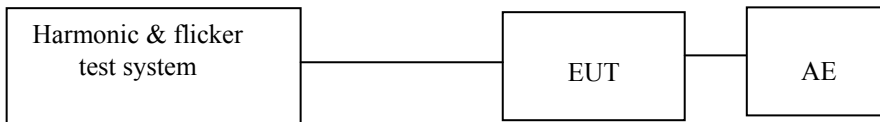

### 6.3 Test Setup and Procedure

#### 6.3.1 Definition

- Flicker: impression of unsteadiness of visual sensation induced by a lighting stimulus whose luminance or spectral distribution fluctuates with time.
- Pst: Short-term flicker indicator The flicker severity evaluated over a short period (in minutes); Pst=1 is the conventional threshold of irritability
- Plt: long-term flicker indicator; the flicker severity evaluated over a long period (a few hours). Using successive Pst value.
- dc: the relative steady-state voltage change
- dmax: the maximum relative voltage change
- d(t): the value during a voltage change

#### 6.3.2 Test condition

The EUT was set to produce the most unfavourable sequence of voltage changes.

**6.4 Test Data**

**Model:EIP036C0500LSD1**

**Flicker Test Summary (Run time)**

**Test Result: Pass**

**Status: Test Completed**

**Pst<sub>i</sub> and limit line**

**European Limits**

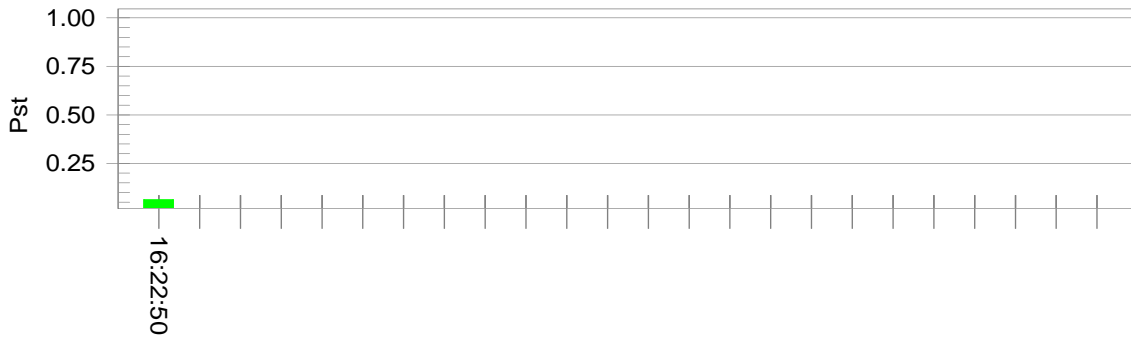

**Time is too short for Plt plot**

**Parameter values recorded during the test:**

<b>Vrms at the end of test (Volt):</b>	<b>229.79</b>		
<b>Highest dt (%):</b>	<b>0.00</b>	<b>Test limit (%):</b>	<b>3.30 Pass</b>
<b>Time(mS) &gt; dt:</b>	<b>0.0</b>	<b>Test limit (mS):</b>	<b>500.0 Pass</b>
<b>Highest dc (%):</b>	<b>0.00</b>	<b>Test limit (%):</b>	<b>3.30 Pass</b>
<b>Highest dmax (%):</b>	<b>0.00</b>	<b>Test limit (%):</b>	<b>4.00 Pass</b>
<b>Highest Pst (10 min. period):</b>	<b>0.064</b>	<b>Test limit:</b>	<b>1.000 Pass</b>

**Model:EIP036C0700LSD1**

**Flicker Test Summary (Run time)**

**Test Result: Pass**

**Status: Test Completed**

**Pst, and limit line**

**European Limits**

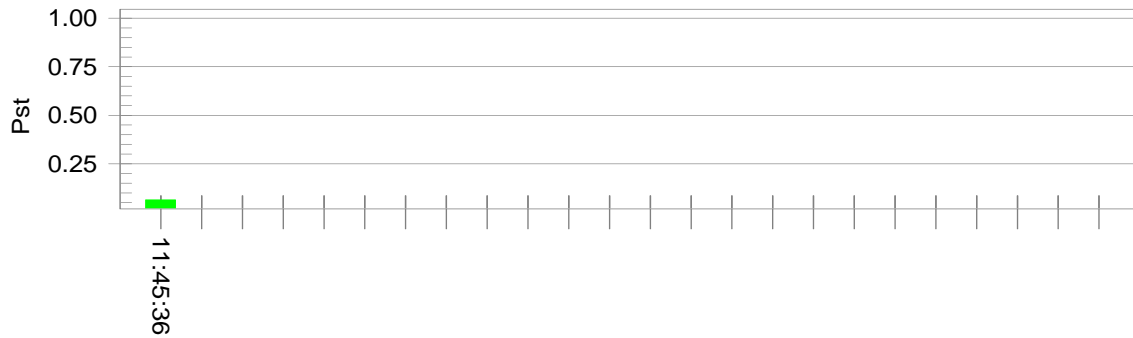

**Time is too short for Plt plot**

**Parameter values recorded during the test:**

<b>Vrms at the end of test (Volt):</b>	<b>229.95</b>			
<b>Highest dt (%):</b>	<b>0.00</b>	<b>Test limit (%):</b>	<b>3.30</b>	<b>Pass</b>
<b>Time(mS) &gt; dt:</b>	<b>0.0</b>	<b>Test limit (mS):</b>	<b>500.0</b>	<b>Pass</b>
<b>Highest dc (%):</b>	<b>0.00</b>	<b>Test limit (%):</b>	<b>3.30</b>	<b>Pass</b>
<b>Highest dmax (%):</b>	<b>0.00</b>	<b>Test limit (%):</b>	<b>4.00</b>	<b>Pass</b>
<b>Highest Pst (10 min. period):</b>	<b>0.064</b>	<b>Test limit:</b>	<b>1.000</b>	<b>Pass</b>

**Model:EIP036C1000LSD1**

**Flicker Test Summary (Run time)**

**Test Result: Pass**

**Status: Test Completed**

**Pst, and limit line**

**European Limits**

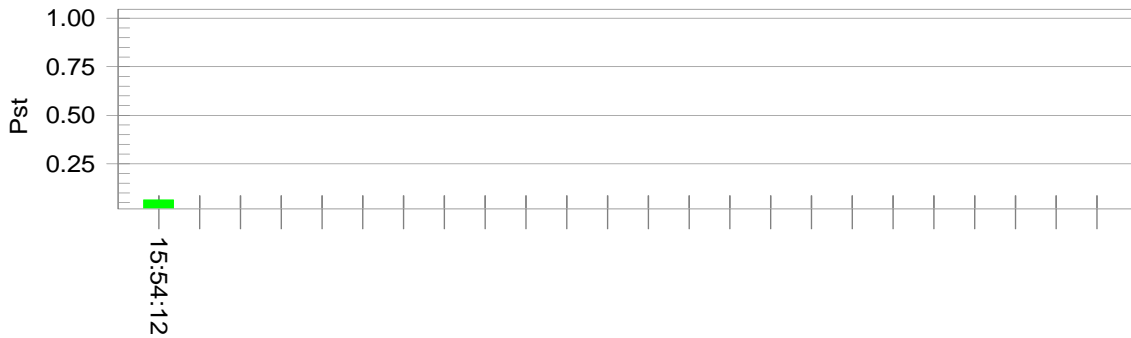

**Time is too short for Plt plot**

**Parameter values recorded during the test:**

<b>Vrms at the end of test (Volt):</b>	<b>229.79</b>			
<b>Highest dt (%):</b>	<b>0.00</b>	<b>Test limit (%):</b>	<b>3.30</b>	<b>Pass</b>
<b>Time(mS) &gt; dt:</b>	<b>0.0</b>	<b>Test limit (mS):</b>	<b>500.0</b>	<b>Pass</b>
<b>Highest dc (%):</b>	<b>0.00</b>	<b>Test limit (%):</b>	<b>3.30</b>	<b>Pass</b>
<b>Highest dmax (%):</b>	<b>0.00</b>	<b>Test limit (%):</b>	<b>4.00</b>	<b>Pass</b>
<b>Highest Pst (10 min. period):</b>	<b>0.064</b>	<b>Test limit:</b>	<b>1.000</b>	<b>Pass</b>

**6.5 Measurement Uncertainty**

Measurement uncertainty for voltage fluctuation and flicker is under consideration according to CISPR 16-4-2:2003.



## 7 EMS TEST

### Performance Criteria:

- Criterion A: During the test no change of the luminous intensity shall be observed and the regulating control, if any, shall operate during the test as intended.
- Criterion B: During the test the luminous intensity may change to any value. After the test the luminous intensity shall be restored to its initial value within 1 min.  
 Regulating controls need not function during the test, but after the test the mode of the control shall be the same as before the test provided that during the test no mode changing commands were given.
- Criterion C: During and after the test any change of the luminous intensity is allowed and the lamp(s) may be extinguished. After the test, within 30 min, all functions shall return to normal if necessary by temporary interruption of the mains supply and /or operating the regulating control.  
 Additional requirement for lighting equipment incorporation a starting device:  
 After the test the lighting equipment is switched off. After half an hour it is witched on again. The lighting equipment shall start and operate as intended.

### **Measurement Uncertainty**

According to CISPR 16-4-2:2003, measurement uncertainty to immunity test is under consideration.

*Note: "N/A" means Not Applicable in below text.*

### **7.1 EN 61000-4-2(Pursuant to EN 61547) Electrostatic Discharge Immunity**

**Performance criterion: B**

**Test Result: Pass**

#### **7.1.1 Used Test Equipment**

Equip. No.	Equipment	Model	Manufacturer
EM077-02	ESD Simulator	NSG435	SCHAFFNER

### 7.1.2 Block Diagram of Test Setup

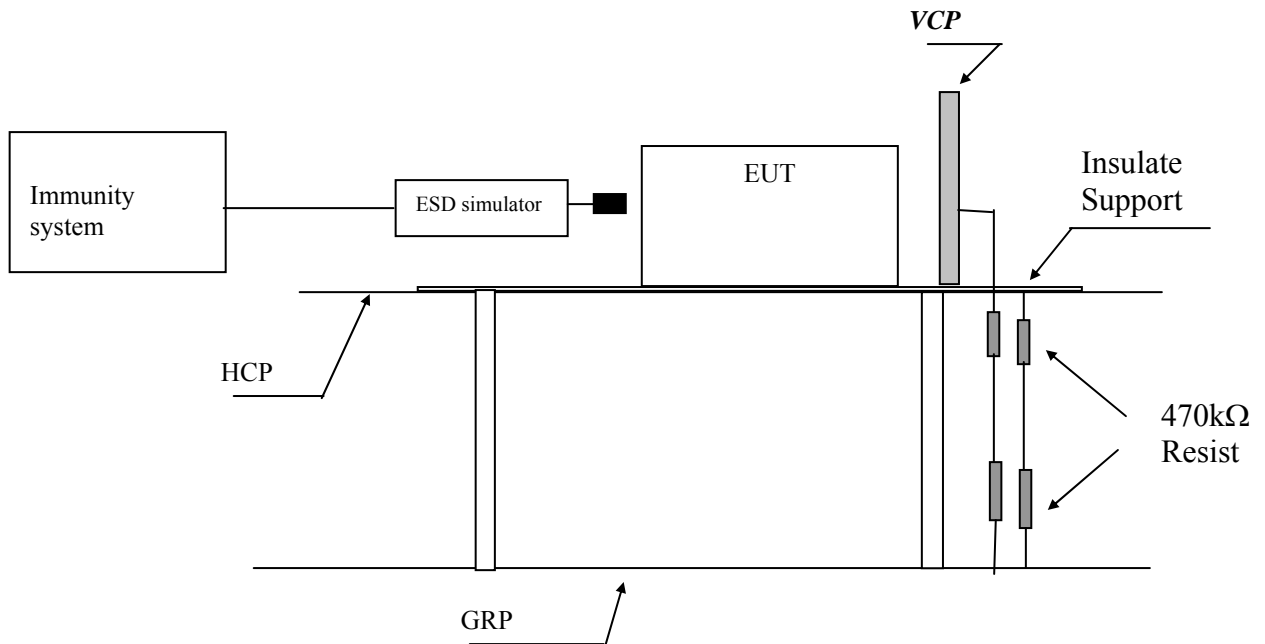

Note: HCP means Horizontal Coupling Plane,  
 VCP means Vertical Coupling Plane  
 GRP means Ground Reference Plane

### 7.1.3 Test Setup and Procedure

The EUT was put on a  $(0,8 \pm 0,08)$  m high wooden table/0.1m high for floor standing equipment standing on the ground reference plane (GRP) 3m by 2m in size, made by iron 1.0 mm thick. A horizontal coupling plane (HCP)  $(1,6 \pm 0,02)$  m by  $(0,8 \pm 0,02)$  m in size was placed on the table, and the EUT with its cables were isolated from the HCP by an insulating support with  $(0.5 \pm 0.05)$  mm thick. The VCP 0.5m by 0.5m in size & HCP were constructed from the same material type & thickness as that of the GRP, and connected to the GRP via a 470kΩ resistor at each end.

For floor standing equipment, The EUT shall be isolated from the ground reference plane by an insulating support of 0,05 m to 0,15 m thick. The EUT cables shall be isolated from the ground reference plane by an insulating support of  $(0,5 \pm 0,05)$  mm. This cable isolation shall extend beyond the edge of the EUT isolation.

The distance between EUT and any of the other metallic surface excepted the GRP, HCP & VCP was greater than 0.8m.

The EUT was arranged and connected according to its functional requirements.

Direct static electricity discharges was applied only to those points and surface which are accessible to personnel during normal usage, terminals are excluded.

On each preselected points 10 times of each polarity single discharge were applied .

The ESD generator was held perpendicular to the surface to which the discharge is applied.

The discharge return cable of the generator was kept at a distance of 0.2m whilst the discharge is being applied. During the contact discharges, the tip of the discharge electrode was touch the EUT before the discharge switch is operated. During the air discharges, the round discharge tip of the discharge electrode was approached as fast as possible to touch the EUT.

Indirect discharge was conducted to objects placed near the EUT, simulated by applying the discharges of the ESD generator to a coupling plane, in the contact discharge mode.

After each discharge, the ESD generator was removed from the EUT, the generator is then retriggered for a new single discharge. For ungrounded product, a grounded carbon fibre brush with bleeder resistors ( $2 \times 470 \text{ k}\Omega$ ) in the grounding cable was used after each discharge to remove remnant electrostatic voltage.

10 times of each polarity single discharge were applied to HCP and VCP. The detail selected points are listed in the following table.

**7.1.4 Test Result**

<b>Direct Application of ESD</b>
----------------------------------

Direct Contact Discharge

Applied Voltage (kV)	No. of Discharge for each point	Result (Pursuant to EN 61547)	Discharged Points
4	20	Pass	Accessible metal parts of the EUT Conductive substrate with coating which is not declared to be insulating

Direct Air Discharge

Applied Voltage (kV)	No. of Discharge for each point	Result (Pursuant to EN 61547)	Discharged Points
2, 4, 8	20	Pass	All accessible points where contact discharge cannot be applied such as Displays, Indicators light, Keyboard, Button, Switch, Knob, Air gap, Slots, Hole and so on

<b>Indirect Application of ESD</b>
------------------------------------

Horizontal Coupling Plane under the EUT

Applied Voltage (kV)	No. of Discharge for each point	Result (pursuant to EN 61547)	Discharged Point
4	20	Pass	At the front edge of each HCP opposite the centre point of each unit of the EUT

Vertical Coupling Plane beside the EUT

Applied Voltage (kV)	No. of Discharge for each point	Result (pursuant to EN 61547 criterion B)	Discharged Point
4	20	Pass	The centre of the vertical edge of the coupling plane

**7.2 EN 61000-4-6(Pursuant to EN 61547) Injected Current (0.15 MHz to 80 MHz)**

**Performance criterion: A**

**Test Result: Pass**

**7.2.1 Used Test Equipment**

Equip. No.	Equipment	Model	Manufacturer
EM003-01	Conducted Disturbance Generator	CDG_1020	Dr.Hubert GmbH

**7.2.2 Block Diagram of Test Setup**

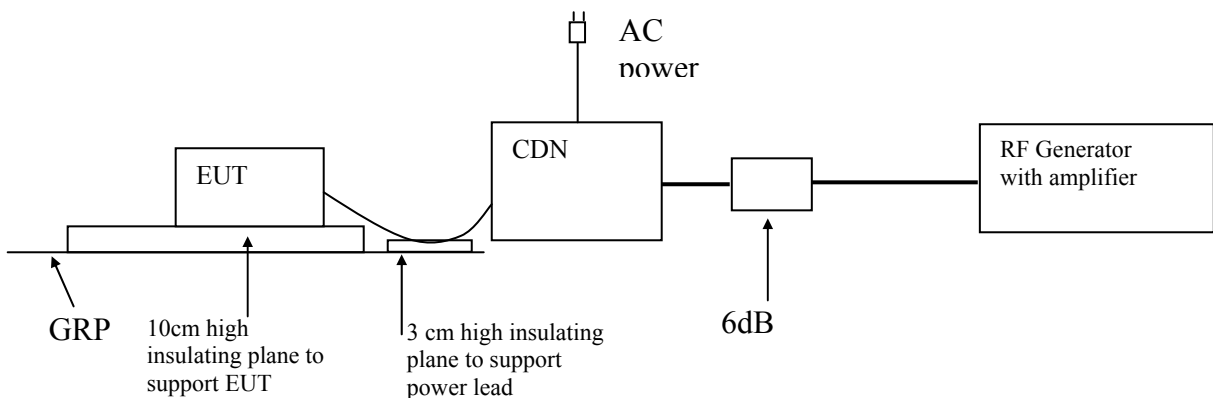

**7.2.3 Test Setup and Procedure**

The EUT was placed on an insulating support of 0.1m height above a ground reference Plane, arranged and connected to satisfy its functional requirement.

All relevant cables were provided with the appropriate coupling and decoupling devices at a distance between 0.1m and 0.3m from the projected geometry of the EUT on an insulating support of 0.03m height above the ground reference plane.

Test voltage was verified before each testing though power meter combined in the RF generator with AMP.

Dwell time was set to 3s and step was set as 1% to keep sufficient response time for EUT.

The frequency from 0.15MHz to 80MHz was checked.

**7.2.4 Test Result**

Port:	Frequency (MHz)	Level (Pursuant to EN 61547)	Result
A.C. Power Lines	0.15 to 80	3V (r.m.s.)	Pass
D.C. Power Lines	0.15 to 80	3V (r.m.s.)	N/A
Signal Lines	0.15 to 80	3V (r.m.s.)	N/A
Control Lines	0.15 to 80	3V (r.m.s.)	N/A

**7.3 EN 61000-4-4(Pursuant to EN 61547) Electrical Fast Transient/Burst**

**Performance criterion: B**  
**Test Result: Pass**

**7.3.1 Used Test Equipment**

Equipment No.	Equipment	Model	Manufacturer
EM005-07	EMS test system	Ecompact 4	HAEFELY

**7.3.2 Block Diagram of Test Setup**

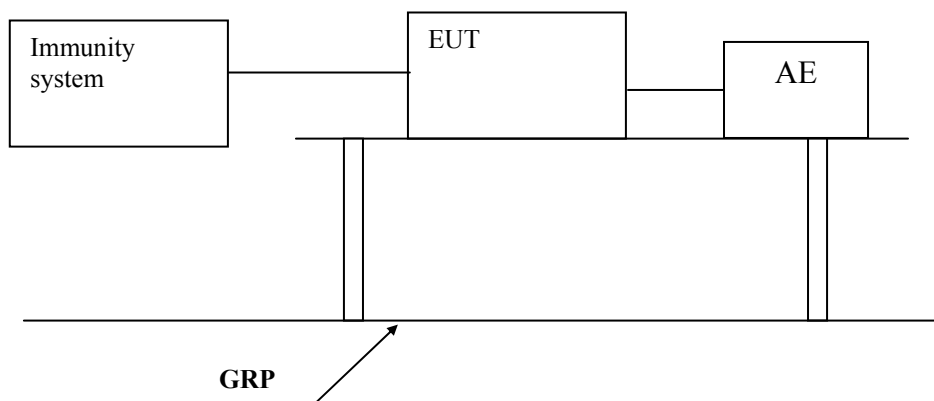

**7.3.3 Test Setup and Procedure**

The EUT was placed on a 0.1m high wooden table, standing on the ground reference plane 3m by 2m in size, made by steel 1mm thick.

The distance between the EUT and any other of the metallic surface except the GRP is greater than 0.5m.

The mains lead excess than 0.5m is folded to avoid a flat coil and situated at a distance of 0.1m above the ground reference plane to insure the distance between the coupling device and the EUT were 0.5m.

The EUT was arranged and connected to satisfy its functional requirement and supplied by the coupling-decoupling network.

**7.3.4 Test Result**

Level (Pursuant to EN 61547)	Polarity	Input and Output A.C. Power Ports	D.C. Power Ports, Signal and Control Lines
0.5kV	+	N/A	N/A
0.5kV	-	N/A	N/A
1kV	+	Pass	N/A
1kV	-	Pass	N/A



**7.4 EN 61000-4-5(Pursuant to EN 61547) Surge Immunity**

**Performance criterion:**  C  
 B (luminaire for emergency lighting)

**Test Result: Pass**

**7.4.1 Used Test Equipment**

Equipment No.	Equipment	Model	Manufacturer
EM005-09	Surge/DIP Generator	NSG3040	TESEQ

**7.4.2 Block Diagram of Test Setup**

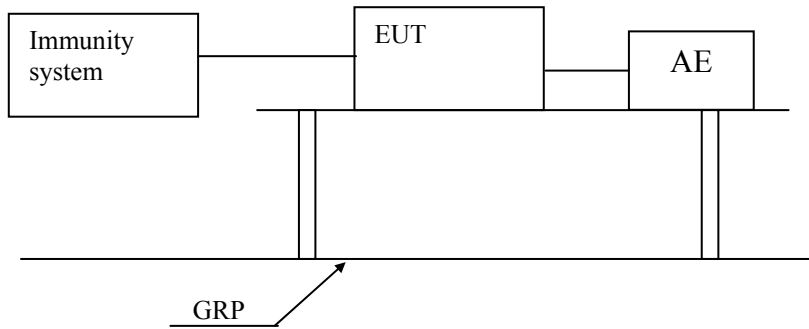

**7.4.3 Test Setup and Procedure**

The surge is to be applied to the EUT power supply terminals via the capacitive coupling network.

Decoupling networks are required in order to avoid possible adverse effects on equipment not under test that may be powered by the same lines and to provide sufficient decoupling impedance to the surge wave so that the specified wave may be developed on the lines under test.

The EUT was arranged and connected according to its functional requirements.

The EUT was placed on a 0.1m high wooden support above the GRP), supplied by the coupling-decoupling network, and arranged and connected to satisfy its functional requirement. The power cord between the EUT and the coupling/decoupling network was less than 2 meters.

Five positive and five negative pulses shall be applied at the peak value and zero crossing points of the a.c. voltage wave.

**7.4.4 Test Result**

I. For Self-ballasted lamps and semi-luminaires and independent auxiliaries with input power less or equal to 25 W:

Level (Pursuant to EN 61547)	Result
Between Phase And Phase: 0.5 kV	N/A
Between Phase And Neutral: 0.5 kV	N/A
Between Phase And Earth: 0.5 kV, 1.0 kV	N/A
Between Neutral And Earth: 0.5 kV, 1.0 kV	N/A

II. For luminaires and independent auxiliaries with input power greater than 25 W:

Level (Pursuant to EN 61547)	Result
Between Phase And Phase: 0.5 kV, 1.0 kV	N/A
Between Phase And Neutral: 0.5 kV, 1.0 kV	Pass
Between Phase And Earth: 0.5 kV, 1.0 kV, 2.0 kV	N/A
Between Neutral And Earth: 0.5 kV, 1.0 kV, 2.0 kV	N/A

**7.5 EN 61000-4-11(Pursuant to EN 61547) Voltage Dips and Interruptions**

**Performance criterion:**

for table 11 of EN 61547 ----- **C**

for table 12 of EN 61547----- **B**

**Test Result: Pass**

**7.5.1 Used Test Equipment**

Equipment No.	Equipment	Model	Manufacturer
EM005-07	EMS test system	Ecompact 4	HAEFELY

**7.5.2 Block Diagram of Test Setup**

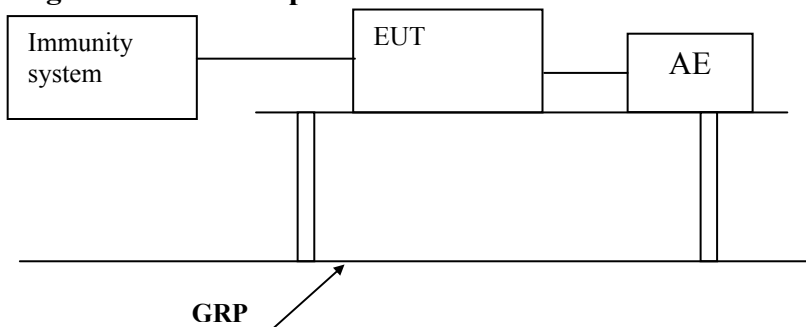

**7.5.3 Test Setup and Procedure**

The EUT was placed on an insulating support of 0.8m height, standing on a ground reference plane, and arranged and connected to satisfy its functional requirement

The test was performed with the EUT connected to the test generator with the shortest power supply cable as specified by the EUT manufacturer.

The EUT was tested for each selected combination of test level and duration with a sequence of three dips/interruptions with intervals of 10 s minimum. Each representative mode of operation was tested.

EUT is tested for voltage reduction of 0%Ut, 0.5 period, 70%Ut, 10 periods, both the positive and negative polarity test was conducted.

Changes to the voltage level shall occur at a zero crossing point in the a.c. voltage waveform.

**7.5.4 Test Result**

I. According to table 11 of EN 61547

Test condition (Pursuant to EN 61547)		Result
Test Level in %U <sub>T</sub>	Duration (in period of the rated frequency)	
70	10	Pass

II. According to table 12 of EN 61547

Test condition (Pursuant to EN 61547)		Result
Test Level in %U <sub>T</sub>	Duration (in period of the rated frequency)	
0	0.5	Pass

Remark: U<sub>T</sub> is the rated voltage for the equipment.



### 7.6.3 Test Setup and Procedure

The test was conducted in an fully anechoic chamber to maintain a uniform field of sufficient dimensions with respect to the EUT, and also in order to comply with various national and international laws prohibiting interference to radio communications.

The equipment is placed in the test facility on a non-conducting table 0.8m high (for floor standing EUT, is placed on a non-conducting support 0.1m height).

The EUT was placed on the uniform calibrated plane which is 3V/m EM field.

For all ports connected to EUT, manufacturer specified cable type and length was used, for those cables no specification, unshielded cable applied.

Wire is left exposed to the electromagnetic field for a distance of 1m from the EUT.

The EUT was arranged and connected according to its functional requirements

Before testing, the intensity of the established field strength have been checked by placing the field sensor at a calibration grid point, and with the field generating antenna and cables in the same positions as used for the calibration, the forward power needed to give the calibrated field strength was measured.

Spot checks was made at a number of calibration grid points over the frequency range 80MHz to 1000MHz, both polarizations was checked.

After calibration, the EUT is initially placed with one face coincident with the calibration plane.

The frequency range is swept from 80MHz to 1000MHz, with the signal 80% amplitude modulated with a 1 kHz sinewave, pausing to adjust the r.f. signal level.

The dwell time at each frequency was 3s so as that the EUT to be exercised and be able to respond.

The step size was 1% of the fundamental with linear interpolation between calibrated points. Test was performed with the generating antenna facing each of the four sides of the EUT.

### 7.6.4 Test Result

Frequency (MHz)	Exposed Side	Field Strength (V/m)	Result
80 to 1000	Front	3V/m (r.m.s.)	Pass
80 to 1000	Left	3V/m (r.m.s.)	Pass
80 to 1000	Rear	3V/m (r.m.s.)	Pass
80 to 1000	Right	3V/m (r.m.s.)	Pass

**8 Appendix I - Photos of test setup**

Conducted Emission



Radiated Electromagnetic Filed Disturbance



Radiated electromagnetic disturbance (9 kHz -30 MHz)

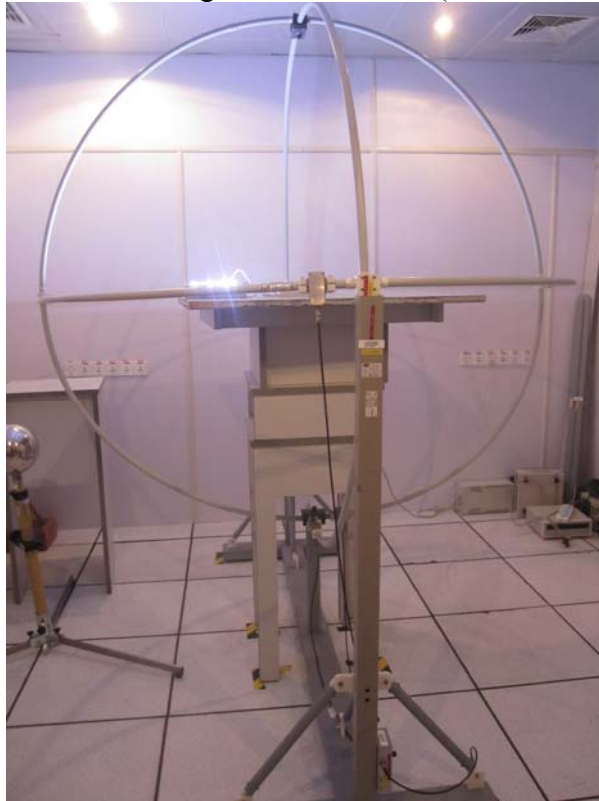

Harmonics and Flicker



ESD Immunity

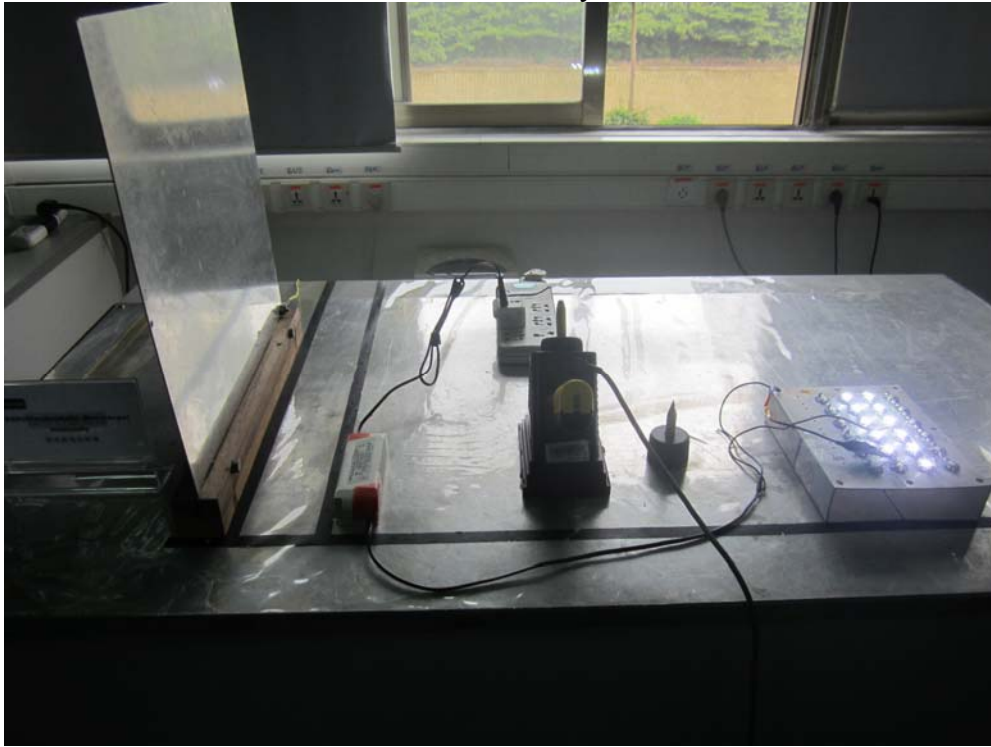

EFT/DIP Immunity





SURGE Immunity

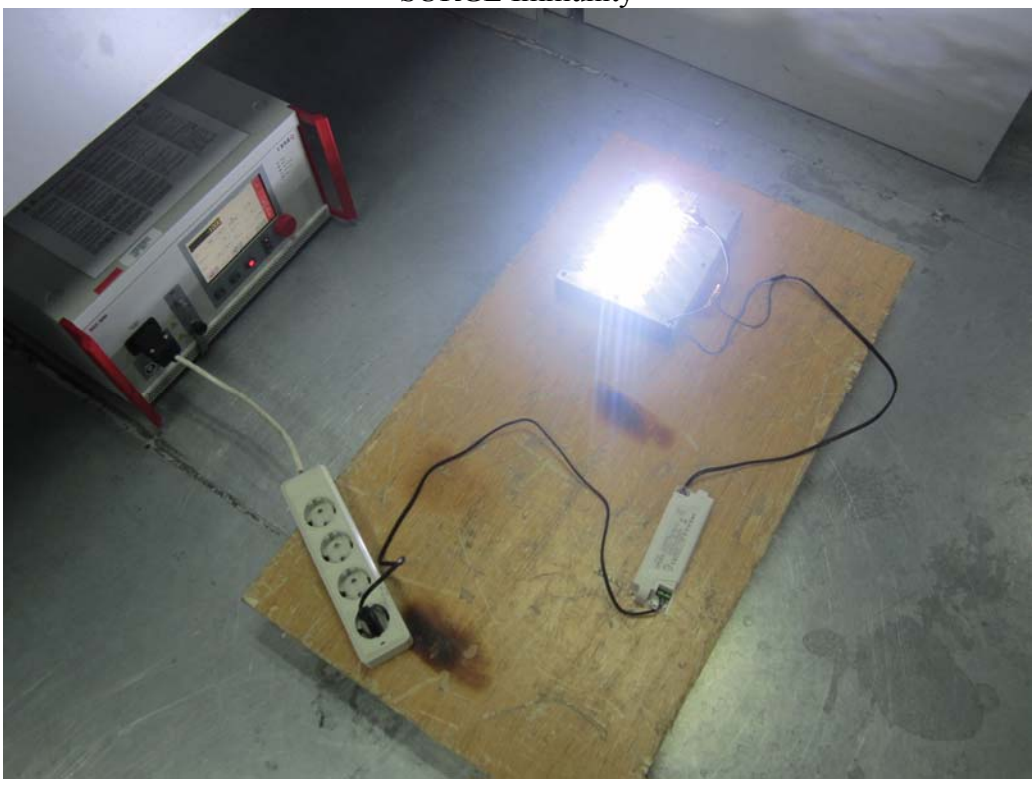

Conducted Immunity

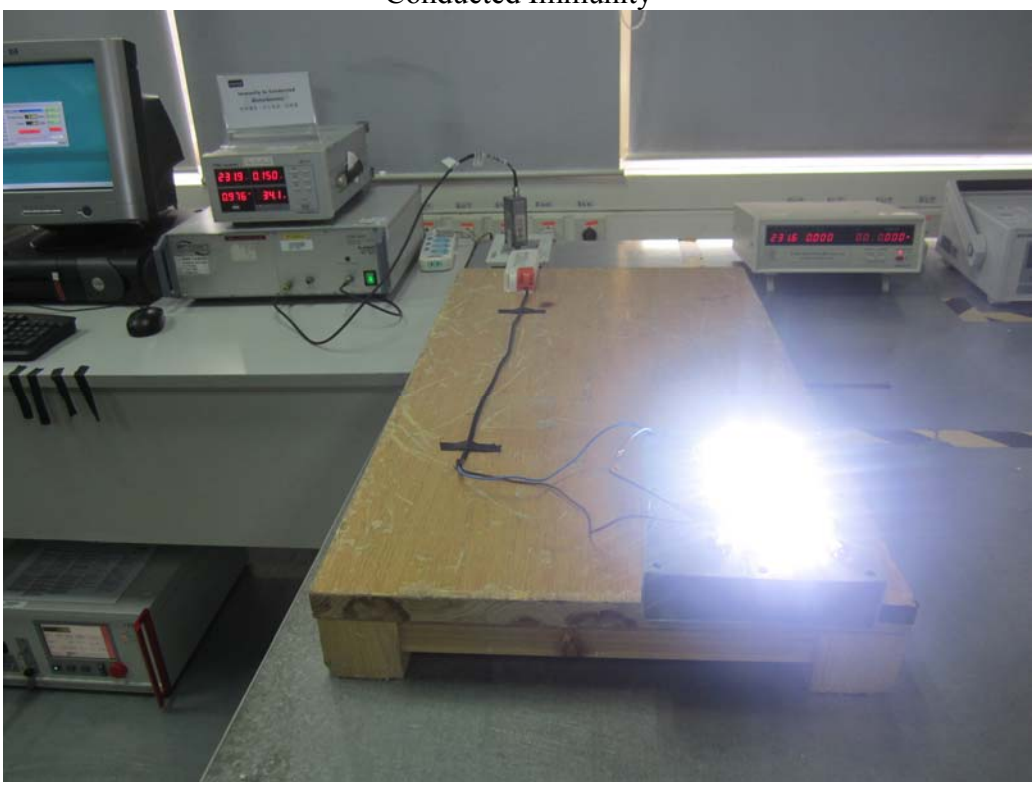

Radiated field Immunity

