

CE EMC Test Report



(Declaration of Conformity)

For

Electromagnetic Interference

Of

Product : LED Power Supply

Trade Name :  **EAGLERISE**

Model Number : ELP040C****LS ("****" is for the output current and represents the number from 0700 to 1400 increasing in multiples of 50.);
ELP050C****LS ("****" is for the output current and represents the number from 0700 to 1500 increasing in multiples of 50.)

Prepared for

Eaglerise Electronics (Foshan) Co., Ltd.

No. 4, East Huanzhen Road, Beijiao, Shunde, Foshan,
Guangdong, 528000, China

Prepared by

NTEK Testing Technology Co., Ltd.

1/F, Building E, Fenda Science Park, Sanwei Community, Xixiang Street,
Bao'an District, Shenzhen P.R. China

Tel.: +86-0755-61156588 Fax.: +86-0755-61156599

Website: www.ntek.org.cn

TEST RESULT CERTIFICATION

Applicant's name : Eaglerise Electronics (Foshan) Co., Ltd.
Address : No. 4, East Huanzhen Road, Beijiao, Shunde, Foshan,
Guangdong, 528000, China

Manufacturer's Name : Eaglerise Electronics (Foshan) Co., Ltd.
Address : No. 4, East Huanzhen Road, Beijiao, Shunde, Foshan,
Guangdong, 528000, China

Product description

Product name : LED Power Supply

Model and/or type reference : ELP040C****LS ("****" is for the output current and represents the number from 0700 to 1400 increasing in multiples of 50.);
ELP050C****LS ("****" is for the output current and represents the number from 0700 to 1500 increasing in multiples of 50.)

Standards : EN 55015:2006+A1:2007+A2:2009
EN 61547:2009
EN 61000-3-2:2006+A1:2009+A2:2009
EN 61000-3-3:2008

This device described above has been tested by NTEK, and the test results show that the equipment under test (EUT) is in compliance with the 2004/108/EC requirements. And it is applicable only to the tested sample identified in the report.

This report shall not be reproduced except in full, without the written approval of NTEK, this document may be altered or revised by NTEK, personal only, and shall be noted in the revision of the document.

Date of Test :
Date (s) of performance of tests : 06 Jul. 2012~18 Jul. 2012
Date of Issue : 18 Jul. 2012
Test Result : **Pass**

Testing Engineer : Apple Huang
(Apple Huang)

Technical Manager : Jim He
(Jim He)

Authorized Signatory : Bovey Yang
(Bovey Yang)

Table of Contents	Page
1 . TEST SUMMARY	6
1.1 TEST FACILITY	7
1.2 MEASUREMENT UNCERTAINTY	7
2 . GENERAL INFORMATION	8
2.1 GENERAL DESCRIPTION OF EUT	8
2.2 DESCRIPTION OF TEST MODES	9
2.3 DESCRIPTION OF TEST SETUP	10
2.4 DESCRIPTION TEST PERIPHERAL AND EUT PERIPHERAL	11
2.5 MEASUREMENT INSTRUMENTS LIST	12
3 . EMC EMISSION TEST	14
3.1 CONDUCTED EMISSION MEASUREMENT	14
3.1.1 POWER LINE CONDUCTED EMISSION	14
3.1.2 LOAD TERMINAL CONDUCTED EMISSION	14
3.1.3 CONTROL TERMINAL CONDUCTED EMISSION	14
3.1.4 TEST PROCEDURE	15
3.1.5 TEST SETUP	15
3.1.6 EUT OPERATING CONDITIONS	15
3.1.7 TEST RESULTS	16
3.2 RADIATED EMISSION MEASUREMENT	18
3.2.1 LIMITS OF RADIATED EMISSION MEASUREMENT	18
3.2.2 TEST PROCEDURE	18
3.2.3 TEST SETUP	19
3.2.4 EUT OPERATING CONDITIONS	19
3.2.5 TEST RESULTS(30MHz-300MHz)	20
3.2.6 TEST RESULTS(0.009~30MHz)	22
3.3 HARMONICS CURRENT	25
3.3.1 LIMITS OF HARMONICS CURRENT	25
3.3.1.1 TEST PROCEDURE	26
3.3.1.2 EUT OPERATING CONDITIONS	26
3.3.1.3 TEST SETUP	26
3.3.2 TEST RESULTS	27
3.4 VOLTAGE FLUCTUATION AND FLICKERS	33
3.4.1 LIMITS OF VOLTAGE FLUCTUATION AND FLICKERS	33
3.4.1.1 TEST PROCEDURE	33
3.4.1.2 EUT OPERATING CONDITIONS	33
3.4.1.3 TEST SETUP	33
3.4.2 TEST RESULTS	34

Table of Contents	Page
4 . EMC IMMUNITY TEST	35
4.1 STANDARD COMPLIANCE/SERVIRTY LEVEL/CRITERIA	35
4.2 GENERAL PERFORMANCE CRITERIA	36
4.3 GENERAL PERFORMANCE CRITERIA TEST SETUP	36
4.4 ESD TESTING	37
4.4.1 TEST SPECIFICATION	37
4.4.2 TEST PROCEDURE	37
4.4.3 TEST SETUP	38
4.4.4 TEST RESULTS	39
4.4.5 PHOTO(S) SHOWN THE LOCATION(S) OF ESD EVALUATED	40
4.5 RS TESTING	41
4.5.1 TEST SPECIFICATION	41
4.5.2 TEST PROCEDURE	41
4.5.3 TEST SETU	42
4.5.4 TEST RESULTS	43
4.6 EFT/BURST TESTING	44
4.6.1 TEST SPECIFICATION	44
4.6.2 TEST PROCEDURE	44
4.6.3 TEST SETUP	45
4.6.4 TEST RESULTS	46
4.7 SURGE TESTING	47
4.7.1 TEST SPECIFICATION	47
4.7.2 TEST PROCEDURE	47
4.7.3 TEST SETUP	48
4.7.4 TEST RESULTS	49
4.8 INJECTION CURRENT TESTING	50
4.8.1 TEST SPECIFICATION	50
4.8.2 TEST PROCEDURE	50
4.8.3 TEST SETUP	51
4.8.4 TEST RESULTS	52
4.9 POWER FREQUENCY MAGNETIC FIELD TESTING	53
4.9.1 TEST SPECIFICATION	53
4.9.2 TEST PROCEDURE	53
4.9.3 TEST SETUP	54
4.9.4 TEST RESULTS	55
4.10 VOLTAGE INTERRUPTION/DIPS TESTING	56
4.10.1 TEST SPECIFICATION	56
4.10.2 TEST PROCEDURE	56
4.10.3 TEST SETUP	56

Table of Contents	Page
4.10.4 TEST RESULTS	57
5 . EUT TEST PHOTO	58
ATTACHMENT PHOTOGRAPHS OF EUT	61

1. TEST SUMMARY

Test procedures according to the technical standards:

EMC Emission				
Standard	Test Item	Limit	Judgment	Remark
EN 55015:2006+A2:2009	Conducted Emission	Class B	PASS	
	Radiated Emission	Class B	PASS	
EN61000-3-2:2006+A2:2009	Harmonic Current Emission	Class A or D NOTE (2)	PASS	
EN 61000-3-3:2008	Voltage Fluctuations & Flicker	-----	PASS	
EMC Immunity				
Section EN 61547:2009	Test Item	Performance Criteria	Judgment	Remark
EN 61000-4-2:2009	Electrostatic Discharge	B	PASS	
EN 61000-4-3:2010	RF electromagnetic field	A	PASS	
EN 61000-4-4:2004+A1:2010	Fast transients	B	PASS	
EN 61000-4-5:2006	Surges	B	PASS	
EN 61000-4-6:2009	Injected Current	A	PASS	
EN 61000-4-8:2010	Power Frequency Magnetic Field	A	PASS	
EN 61000-4-11:2004	Volt. Interruptions Volt. Dips	B / C NOTE (3)	PASS	

NOTE:

(1) "N/A" denotes test is not applicable in this Test Report

(2) Voltage dip: 100% reduction – Performance Criteria **B**

Voltage dip: 30% reduction – Performance Criteria **C**

(3) For client's request and manual description, the test will not be executed.

1.1 TEST FACILITY

NTEK Testing Technology Co., Ltd.

Add. : 1/F, Building E, Fenda Science Park, Sanwei Community, Xixiang Street, Bao'an District, Shenzhen P.R. China.

FCC Registration Number: 238937; IC Registration Number: 9270A-1

CNAS Registration Number: L5516

1.2 MEASUREMENT UNCERTAINTY

The reported uncertainty of measurement $y \pm U$, where expanded uncertainty U is based on a standard uncertainty multiplied by a coverage factor of $k=2$, providing a level of confidence of approximately 95 %.

A. Conducted Measurement :

Test Site	Method	Measurement Frequency Range	U , (dB)	NOTE
NTEKC01	ANSI	150 KHz ~ 30MHz	3.2	

B. Radiated Measurement :

Test Site	Method	Measurement Frequency Range	U , (dB)	NOTE
NTEKA01	ANSI	30MHz ~ 1000MHz	4.7	
		1GHz ~6GHz	5.0	

2. GENERAL INFORMATION

2.1 GENERAL DESCRIPTION OF EUT

Equipment	LED Power Supply				
Model Name.	ELP050C1500LS				
Serial No	ELP040C****LS ("****" is for the output current and represents the number from 0700 to 1400 increasing in multiples of 50.); ELP050C****LS ("****" is for the output current and represents the number from 0700 to 1500 increasing in multiples of 50.)				
Model Difference	All models are identical except model names, output informations and device parameters output on some degree.				
Product Description	<p>The EUT is a LED Power Supply.</p> <table border="1" data-bbox="598 869 1390 938"> <tr> <td>Operating frequency:</td> <td>N/A</td> </tr> <tr> <td>Connecting I/O port:</td> <td>N/A</td> </tr> </table> <p>Based on the application, features, or specification exhibited in User's Manual, the EUT is considered as an ITE/Computing Device. More details of EUT technical specification, please refer to the User's Manual.</p>	Operating frequency:	N/A	Connecting I/O port:	N/A
Operating frequency:	N/A				
Connecting I/O port:	N/A				
Power Source	AC Voltage				
Power Rating	Input: 100-240V~, 50/60Hz, Max. 0.45A; Output: Constant Current type; 700-1400mA for ELP040C****LS series; Input: 220-240V~, 50/60Hz, Max. 0.28A; Output: Constant Current type; 700-1500mA for ELP050C****LS series.				

2.2 DESCRIPTION OF TEST MODES

To investigate the maximum EMI emission characteristics generates from EUT, the test system was pre-scanning tested base on the consideration of following EUT operation mode or test configuration mode which possible have effect on EMI emission level. Each of these EUT operation mode(s) or test configuration mode(s) mentioned above was evaluated respectively.

Pretest Mode	Description
Mode 1	On

For Conducted Test	
Final Test Mode	Description
Mode 1	On

For Radiated Test	
Final Test Mode	Description
Mode 1	On

For EMS Test	
Final Test Mode	Description
Mode 1	On

2.3 DESCRIPTION OF TEST SETUP

Mode 1:

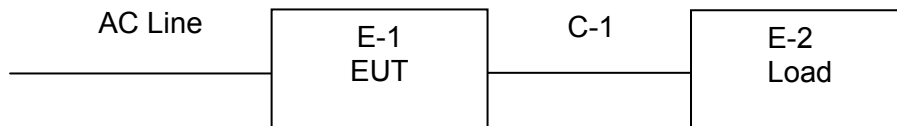

2.4 DESCRIPTION TEST PERIPHERAL AND EUT PERIPHERAL

The EUT has been tested as an independent unit together with other necessary accessories or support units. The following support units or accessories were used to form a representative test configuration during the tests.

Item	Equipment	Mfr/Brand	Model/Type No.	Series No.	Note
E-1	LED Power Supply		ELP050C1500LS	N/A	EUT
E-2	Load	N/A	N/A	N/A	

Item	Shielded Type	Ferrite Core	Length	Note
C-1	NO	NO	30cm	

Note:

- (1) The support equipment was authorized by Declaration of Confirmation.
- (2) For detachable type I/O cable should be specified the length in cm in 『Length』 column.
- (3) “YES” means “shielded” “with core”; “NO” means “unshielded” “without core”.

2.5 MEASUREMENT INSTRUMENTS LIST

2.5.1 CONDUCTED TEST SITE

Item	Kind of Equipment	Manufacturer	Type No.	Serial No.	Calibrated until
1	LISN	R&S	ENV216	101313	Jul. 06, 2013
2	LISN	EMCO	3816/2	00042990	Jul. 06, 2013
3	50Ω Switch	ANRITSU CORP	MP59B	6200983704	Jul. 06, 2013
4	Test Cable	N/A	C01	N/A	Jul. 06, 2013
5	Test Cable	N/A	C02	N/A	Jul. 06, 2013
6	Test Cable	N/A	C03	N/A	Jul. 06, 2013
7	EMI Test Receiver	R&S	ESCI	101160	Jul. 06, 2013
8	Passive Voltage Probe	ESH2-Z3	R&S	100196	Jul. 06, 2013
9	Triple-Loop Antenna	EVERFINE	LIA-2	11020003	Jul. 06, 2013
10	Absorbing Clamp	R&S	MDS-21	100423	Jul. 08, 2013

2.5.2 RADIATED TEST SITE

Item	Kind of Equipment	Manufacturer	Type No.	Serial No.	Calibrated until
1	Bilog Antenna	TESEQ	CBL6111D	31216	Jul. 06, 2013
2	Test Cable	N/A	R-01	N/A	Jul. 06, 2013
3	Test Cable	N/A	R-02	N/A	Jul. 06, 2013
4	EMI Test Receiver	R&S	ESCI-7	101318	Jul. 06, 2013
5	Antenna Mast	EM	SC100_1	N/A	N/A
6	Turn Table	EM	SC100	060531	N/A
7	50Ω Switch	Anritsu Corp	MP59B	6200983705	Jul. 06, 2013
8	Spectrum Analyzer	Aglient	E4407B	MY45108040	Jul. 06. 2013
9	Horn Antenna	EM	EM-AH-1018 0	2011071402	Jul. 06. 2013
10	Amplifier	EM	EM-30180	060538	Jul. 06. 2013

2.5.3 HARMONICS AND FILCK

Item	Kind of Equipment	Manufacturer	Type No.	Serial No.	Calibrated until
1	Harmonic & Flicker	EM TEST	DPA500	0303-04	Jul. 06, 2013
2	AC Power Source	EM TEST	ACS500	0203-01	Jul. 06, 2013

2.5.4 ESD

Item	Kind of Equipment	Manufacturer	Type No.	Serial No.	Calibrated until
1	ESD TEST GENERATOR	EVERFINE	EMS61000-2 A-V200	11040001T	Jul. 06, 2013

2.5.5 RS

Item	Kind of Equipment	Manufacturer	Type No.	Serial No.	Calibrated until
1	Signal Generator	R&S	SMT 06	832080/007	Jul. 24, 2012
2	Log-Bicon Antenna	Schwarzbeck	VULB9161	4022	Aug. 15, 2012
3	Power Amplifier	AR	150W1000M1	320946	Sep. 23, 2012
4	Microwave Horn Antenna	AR	AT4002A	321467	Jun. 11, 2013
5	Power Amplifier	AR	25S1G4A	308598	Sep. 23, 2012

2.5.6 SURGE, EFT/BURST, VOLTAGE INTERRUPTION/DIPS

Item	Kind of Equipment	Manufacturer	Type No.	Serial No.	Calibrated until
1	Surge Generator	EVERFINE	EMS61000-5 A	1101002	Jul. 06, 2013
2	DIPS Generator	EVERFINE	EMS61000-1 1K	1011002	Jul. 06, 2013
3	EFT/B Generator	EVERFINE	EMS61000-4 A-V2	1012005	Aug. 04, 2012

2.5.7 INJECTION CURRENT

Item	Kind of Equipment	Manufacturer	Type No.	Serial No.	Calibrated until
1	Signal Generator	IFR	2023A	202301/368	Mar. 31, 2013
2	Power Amplifier	AR	75A250AM1	0320709	Sep. 23, 2012
3	CDN	FCC	FCC-801-M2	06043	Jun. 02, 2013
4	EM Clamp	FCC	F-203I-23MM	504	Jun. 09, 2013

2.4.8 MF

Item	Kind of Equipment	Manufacturer	Type No.	Serial No.	Calibrated until
1	Generator	EVERFINE	EMS61000-8 K	1007001	Jul. 06, 2013

3. EMC EMISSION TEST

3.1 CONDUCTED EMISSION MEASUREMENT

3.1.1 POWER LINE CONDUCTED EMISSION (Frequency Range 9KHz-30MHz)

FREQUENCY (MHz)		
	Quasi-peak	Average
0.009-0.05	110	
0.05-0.15	90 - 80 *	
0.15 -0.5	66 - 56 *	56 - 46 *
0.50 -5.0	56.00	46.00
5.0 -30.0	60.00	50.00

Note:

- (1) The tighter limit applies at the band edges.
- (2) The limit of " * " marked band means the limitation decreases linearly with the logarithm of the frequency in the range.

3.1.2 LOAD TERMINAL CONDUCTED EMISSION (Frequency Range 150KHz-30MHz)

FREQUENCY (MHz)		
	Quasi-peak	Average
0.15 -0.5	80	70
0.50 -30.0	74	64

Note:

- (1) The tighter limit applies at the band edges.

3.1.3 CONTROL TERMINAL CONDUCTED EMISSION (Frequency Range 150KHz-30MHz)

FREQUENCY (MHz)		
	Quasi-peak	Average
0.15 -0.5	84 - 74*	74 - 64*
0.50 -30.0	74	64

Note:

- (1) The tighter limit applies at the band edges.
- (2) The limit of " * " marked band means the limitation decreases linearly with the logarithm of the frequency in the range.

The following table is the setting of the receiver

Receiver Parameters	Setting
Attenuation	10 dB
Start Frequency	0.009 MHz
Stop Frequency	30 MHz
IF Bandwidth	200Hz and 9 kHz

3.1.4 TEST PROCEDURE

- a. The EUT was placed 0.4 meters from the horizontal ground plane with EUT being connected to the power mains through a line impedance stabilization network (LISN). All other support equipments powered from additional LISN(s). The LISN provide 50 Ohm/ 50uH of coupling impedance for the measuring instrument.
- b. Interconnecting cables that hang closer than 40 cm to the ground plane shall be folded back and forth in the center forming a bundle 30 to 40 cm long.
- c. I/O cables that are not connected to a peripheral shall be bundled in the center. The end of the cable may be terminated, if required, using the correct terminating impedance. The overall length shall not exceed 1 m.
- d. LISN at least 80 cm from nearest part of EUT chassis.
- e. For the actual test configuration, please refer to the related Item –EUT Test Photos.

3.1.5 TEST SETUP

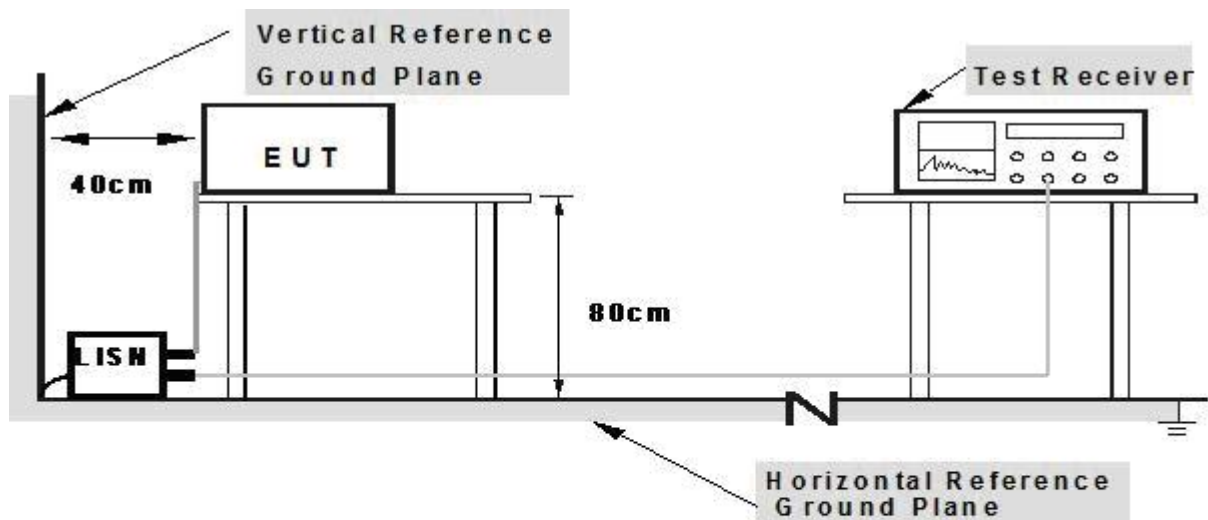

Note: 1. Support units were connected to second LISN.

2. Both of LISNs (AMN) are 80 cm from EUT and at least 80 cm from other units and other metal planes

3.1.6 EUT OPERATING CONDITIONS

The EUT tested system was configured as the statements of 2.3 Unless otherwise a special operating condition is specified in the follows during the testing.

3.1.7 TEST RESULTS

EUT :	LED Power Supply	Model Name. :	ELP050C1500LS
Temperature :	26 °C	Relative Humidity :	54%
Pressure :	1010hPa	Test Date :	2012-07-16
Test Mode :	On	Phase :	L
Test Voltage :	AC 230V/50Hz		

Freq. (MHz)	Reading (dBuV)	Factor (dBuV)	Measurement (dBuV)	Limit (dBuV)	Over (dB)	Detector
0.538	39.03	10.40	49.43	56.00	-6.57	QP
0.546	19.89	10.40	30.29	46.00	-15.71	AVG
1.562	21.98	10.42	32.40	46.00	-13.60	AVG
1.786	39.82	10.42	50.24	56.00	-5.76	QP

Remark:

1. All readings are Quasi-Peak and Average values.
2. Factor = Insertion Loss + Cable Loss.
3. N/A means All Data have pass Limit

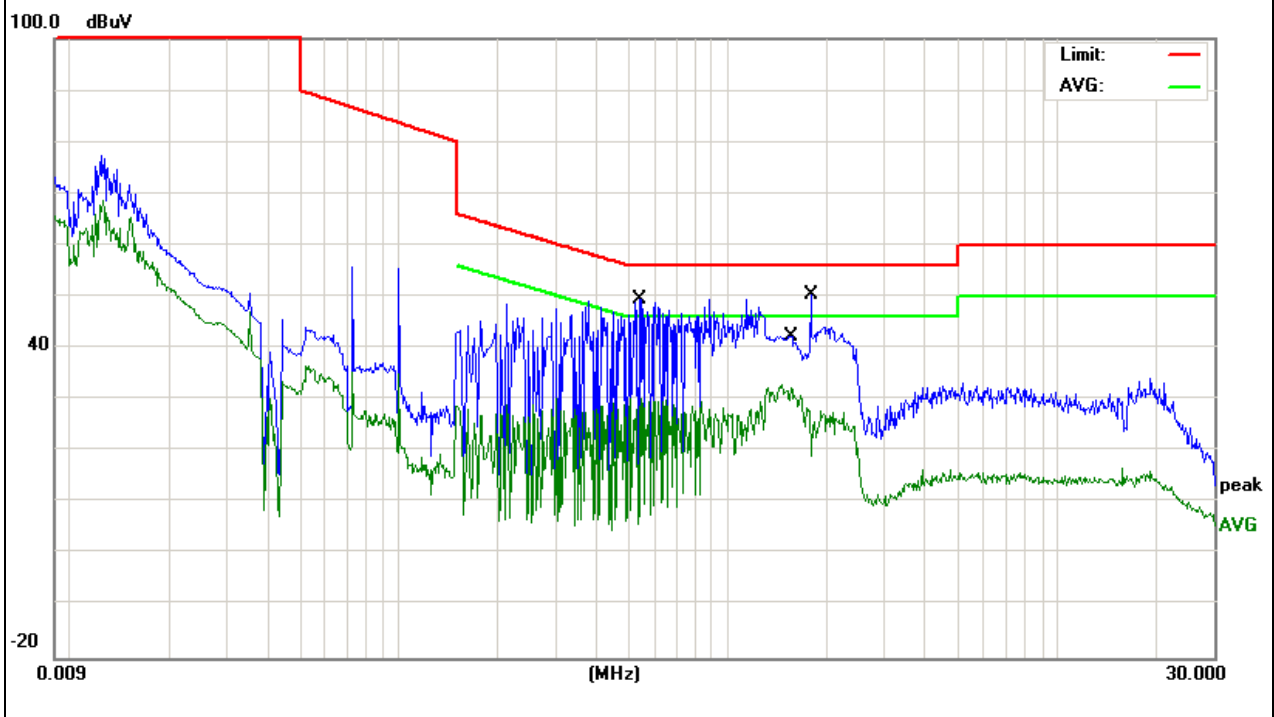

EUT :	LED Power Supply	Model Name. :	ELP050C1500LS
Temperature :	26 °C	Relative Humidity :	54%
Pressure :	1010hPa	Test Date :	2012-07-16
Test Mode :	On	Phase :	N
Test Voltage :	AC 230V/50Hz		

Freq. (MHz)	Reading (dBuV)	Factor (dBuV)	Measurement (dBuV)	Limit (dBuV)	Over (dB)	Detector
0.666	40.64	10.40	51.04	56.00	-4.96	QP
0.666	20.02	10.40	30.42	46.00	-15.58	AVG
1.3899	20.07	10.45	30.52	46.00	-15.48	AVG
1.4459	40.01	10.45	50.46	56.00	-5.54	QP

Remark:

1. All readings are Quasi-Peak and Average values.
2. Factor = Insertion Loss + Cable Loss.
3. N/A means All Data have pass Limit

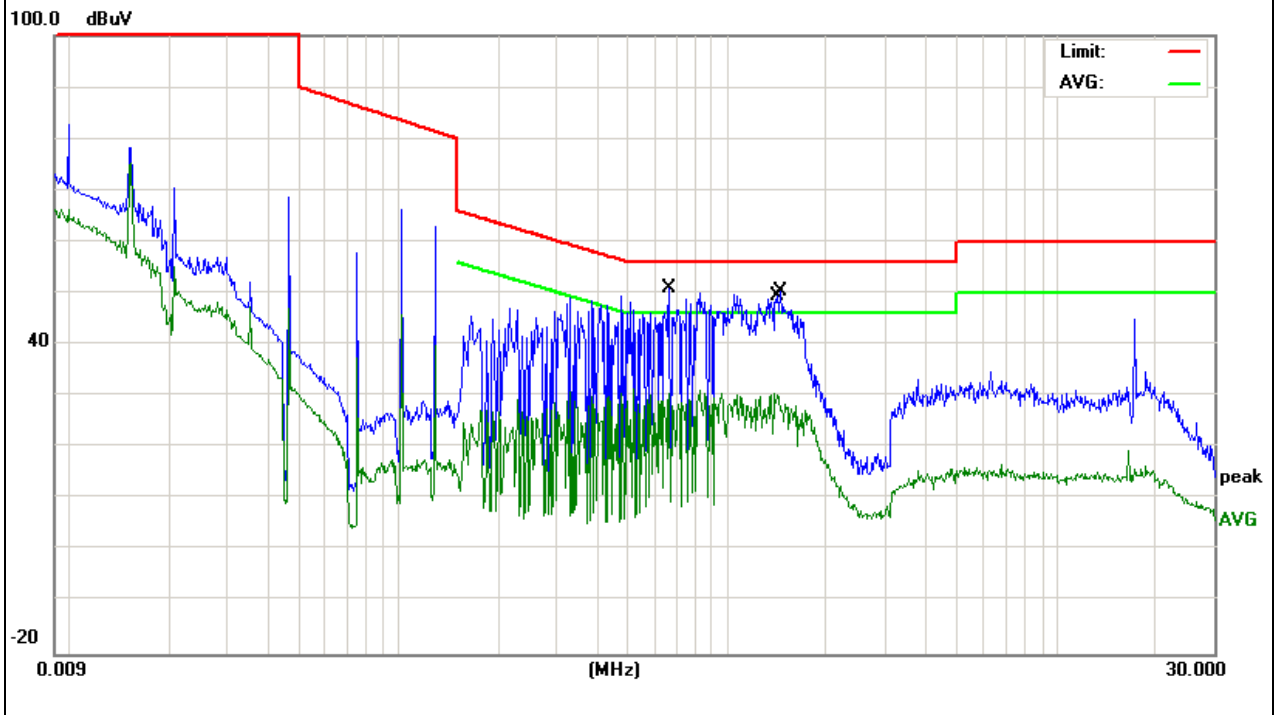

3.2 RADIATED EMISSION MEASUREMENT

3.2.1 LIMITS OF RADIATED EMISSION MEASUREMENT (Below 1000MHz)

FREQUENCY (MHz)	<input checked="" type="checkbox"/> 2m	<input type="checkbox"/> 3m	<input type="checkbox"/> 4m
	dB(μA)	dB(μA)	dB(μA)
9 KHz~ 70 KHz	88	81	75
70 KHz ~ 150 KHz	88 to 58	81 to 51	75 to 45
150 KHz ~ 3 MHz	58 to 22	51 to 15	45 to 9
3 MHz ~ 30 MHz	22	15 to 16	9 to 12

FREQUENCY (MHz)	At 10m	At 3m
	dBuV/m	dBuV/m
30 – 230	30	40
230 – 300	37	47

Notes:

- (1) The limit for radiated test was performed according to as following:
CISPR 15.
- (2) The tighter limit applies at the band edges.
- (3) Emission level (dBuV/m)=20log Emission level (uV/m).

3.2.2 TEST PROCEDURE

- a. The measuring distance of at 10 m shall be used for measurements at frequency up to 1GHz. For frequencies above 1GHz, any suitable measuring distance may be used.
- b. The EUT was placed on the top of a rotating table 0.8 meters above the ground at a 10 meter open area test site. The table was rotated 360 degrees to determine the position of the highest radiation.
- c. The height of the equipment or of the substitution antenna shall be 0.8 m; the height of the test antenna shall vary between 1 m to 4 m. Both horizontal and vertical polarizations of the antenna are set to make the measurement.
- d. The initial step in collecting conducted emission data is a spectrum analyzer peak detector mode pre-scanning the measurement frequency range. Significant peaks are then marked and then Quasi Peak detector mode re-measured, above 1G Average detector mode will be instead.
- e. If the Peak Mode measured value compliance with and lower than Quasi Peak Mode Limit, the EUT shall be deemed to meet QP(AV) Limits and then no additional QP Mode measurement performed.
- f. For the actual test configuration, please refer to the related Item –EUT Test Photos.

3.2.3 TEST SETUP

(A) Radiated Emission Test Set-Up Frequency Below 30 MHz

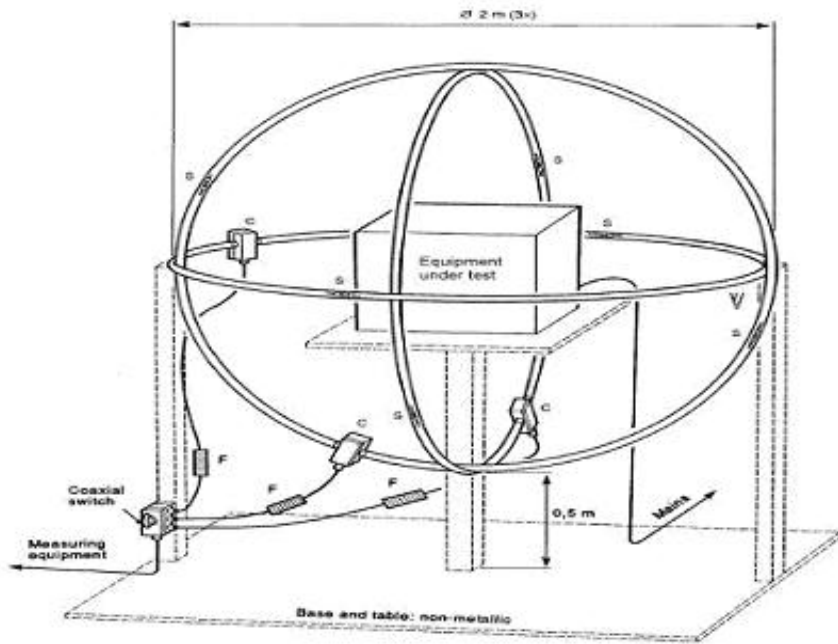

(B) Radiated Emission Test Set-Up Frequency Above 30 MHz

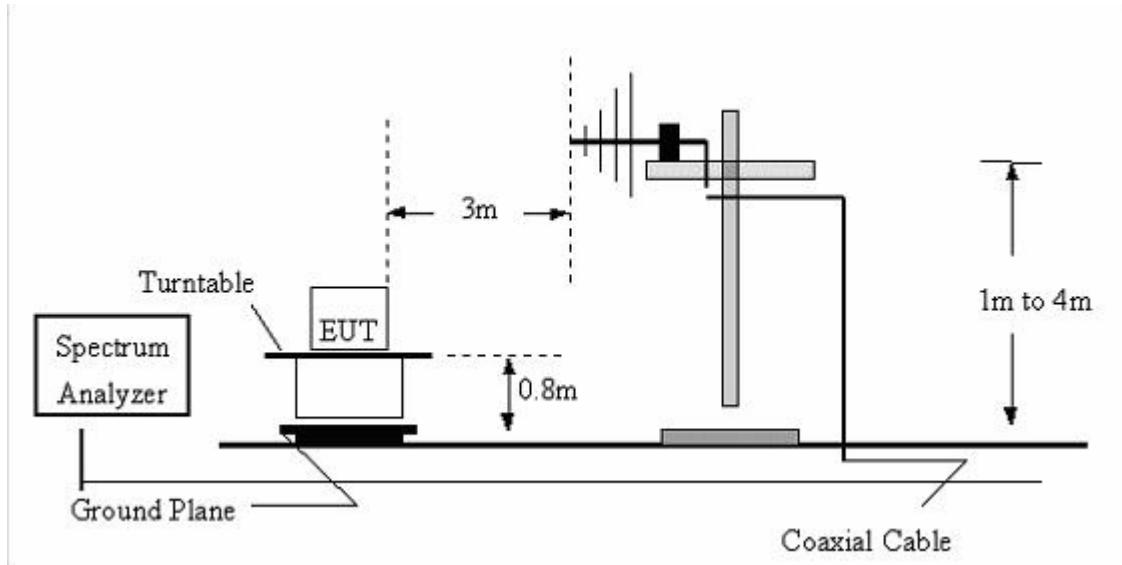

3.2.4 EUT OPERATING CONDITIONS

The EUT tested system was configured as the statements of **2.3** Unless otherwise a special operating condition is specified in the follows during the testing.

3.2.5 TEST RESULTS(30MHz-300MHz)

EUT :	LED Power Supply	Model Name :	ELP050C1500LS
Temperature :	24 °C	Relative Humidity :	54%
Pressure :	1010 hPa	Test Date :	2012-07-16
Test Mode :	On	Polarization :	Horizontal
Test Power :	AC 230V/50Hz		

Freq. (MHz)	Reading (dBuV)	Factor (dBuV)	Measurement (dBuV)	Limit (dBuV)	Over (dB)	Detector
30.0000	16.57	18.33	34.90	40.00	-5.10	QP
44.2712	21.58	11.02	32.60	40.00	-7.40	QP
100.7211	23.31	10.69	34.00	40.00	-6.00	QP

Remark:

1. All readings are Quasi-Peak and Average values.
2. Factor = Antenna Factor + Cable Loss.
3. N/A means All Data have pass Limit

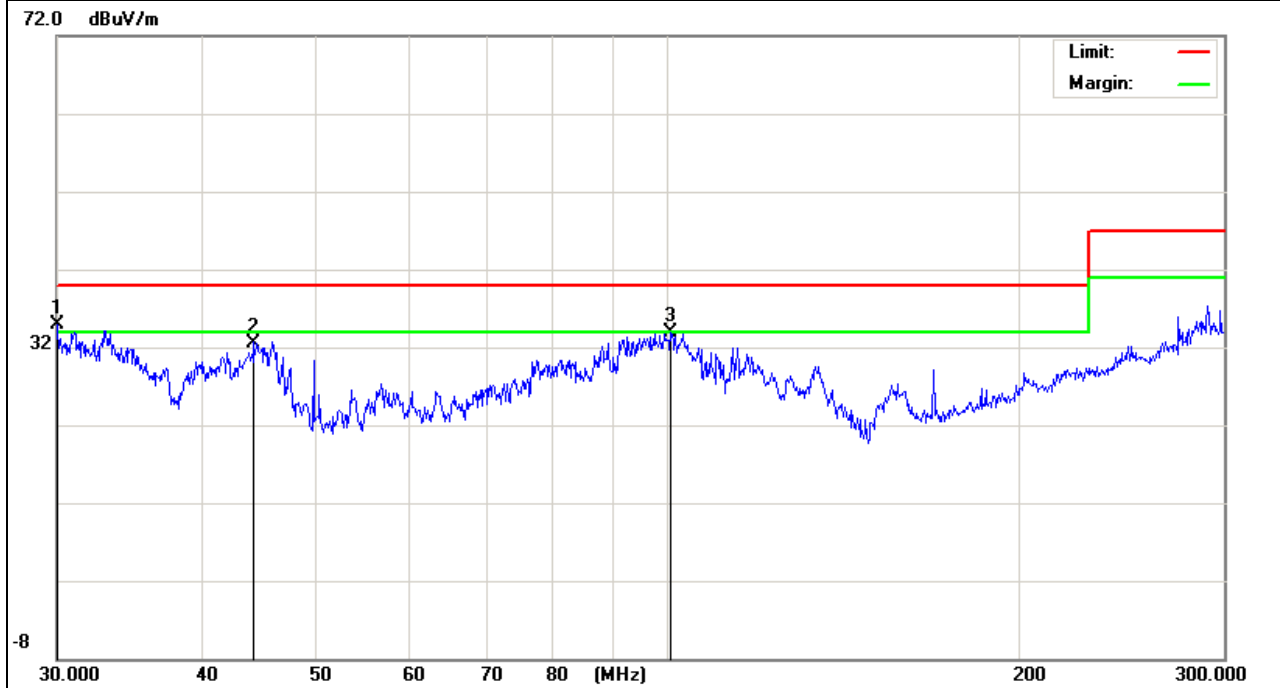

EUT :	LED Power Supply	Model Name :	ELP050C1500LS
Temperature :	24 °C	Relative Humidity :	54%
Pressure :	1010 hPa	Test Date :	2012-07-16
Test Mode :	On	Polarization :	Vertical
Test Power :	AC 230V/50Hz		

Freq. (MHz)	Reading (dBuV)	Factor (dBuV)	Measurement (dBuV)	Limit (dBuV)	Over (dB)	Detector
34.2075	18.64	16.09	34.73	40.00	-5.27	QP
70.1650	29.75	6.06	35.81	40.00	-4.19	QP
80.7459	27.22	7.88	35.10	40.00	-4.90	QP

Remark:

1. All readings are Quasi-Peak and Average values.
2. Factor = Antenna Factor + Cable Loss.
3. N/A means All Data have pass Limit

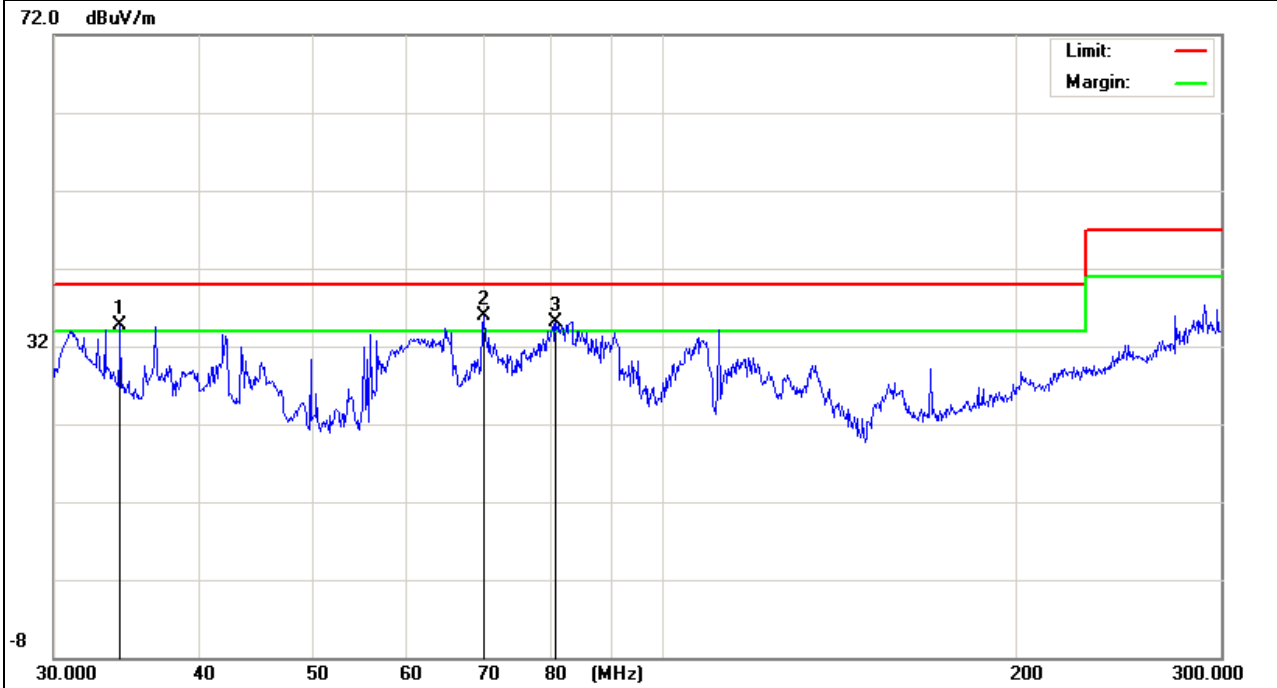

3.2.6 TEST RESULTS(0.009~30MHz)

EUT :	LED Power Supply	Model Name :	ELP050C1500LS
Temperature :	24 °C	Relative Humidity :	54%
Pressure :	1010 hPa	Test Date :	2012-07-16
Test Mode :	On	Polarization :	X
Test Power :	AC 230V/50Hz		

Freq. (MHz)	Reading (dBuV)	Factor (dBuV)	Measurement (dBuV)	Limit (dBuV)	Over (dB)	Detector
0.1269	18.26	15.35	33.61	64.56	-30.95	QP
0.1269	14.73	15.35	30.08	54.56	-24.48	AVG
0.7096	7.28	10.40	17.68	29.48	-11.80	AVG
0.7378	14.88	10.41	25.29	39.01	-13.72	QP
7.1619	5.47	10.68	16.15	22.00	-5.85	QP
7.2660	-3.14	10.68	7.54	12.00	-4.46	AVG

Remark:

1. All readings are Quasi-Peak and Average values.
2. Factor = Antenna Factor + Cable Loss - Amplifier.
3. N/A means All Data have pass Limit

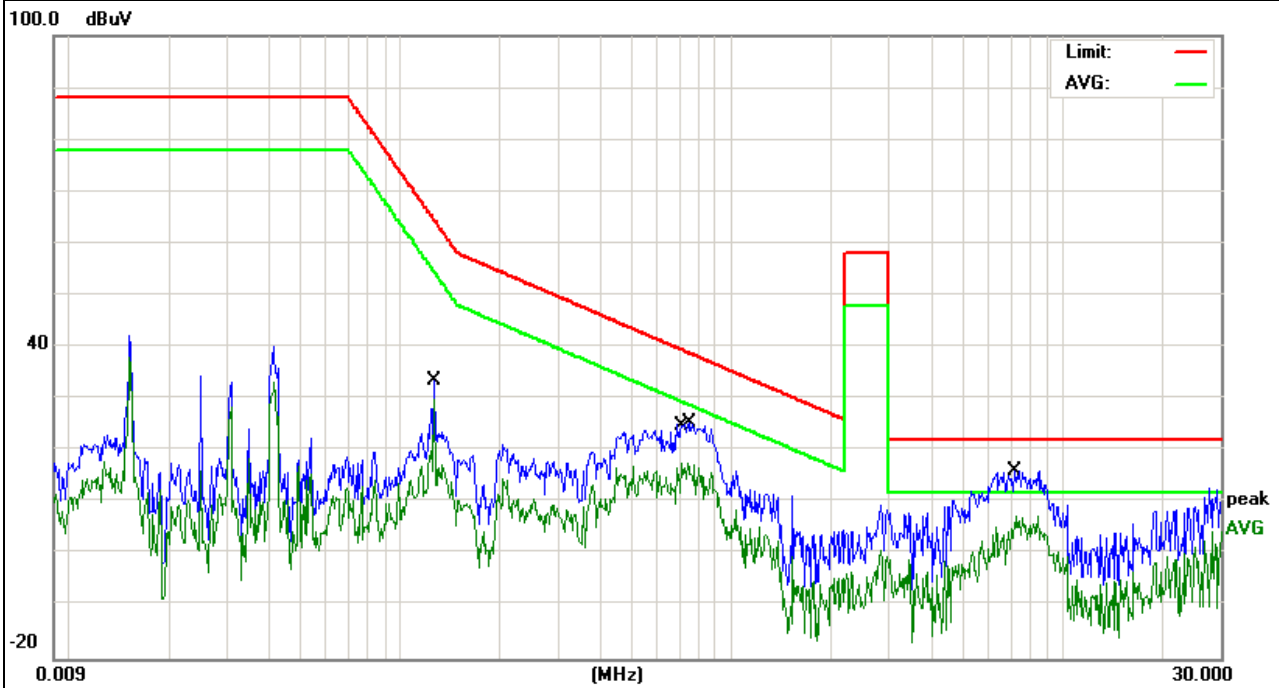

EUT :	LED Power Supply	Model Name :	ELP050C1500LS
Temperature :	24 °C	Relative Humidity :	54%
Pressure :	1010 hPa	Test Date :	2012-07-16
Test Mode :	On	Polarization :	Y
Test Power :	AC 230V/50Hz		

Freq. (MHz)	Reading (dBuV)	Factor (dBuV)	Measurement (dBuV)	Limit (dBuV)	Over (dB)	Detector
0.0417	18.33	15.95	34.28	78.00	-43.72	AVG
0.1269	16.27	15.35	31.62	64.56	-32.94	QP
0.1269	12.73	15.35	28.08	54.56	-26.48	AVG
0.3659	11.06	10.42	21.48	47.37	-25.89	QP
8.3780	-7.13	10.68	3.55	12.00	-8.45	AVG
8.5259	1.99	10.68	12.67	22.00	-9.33	QP

Remark:

1. All readings are Quasi-Peak and Average values.
2. Factor = Antenna Factor + Cable Loss - Amplifier.
3. N/A means All Data have pass Limit

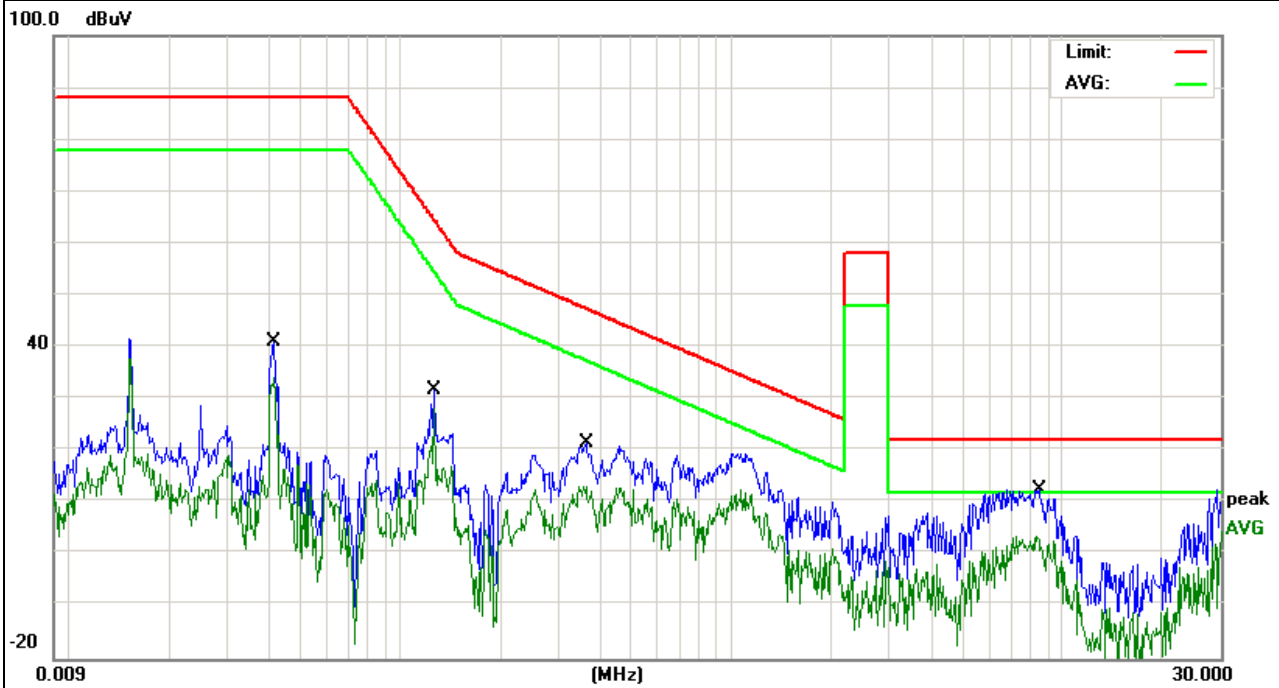

EUT :	LED Power Supply	Model Name :	ELP050C1500LS
Temperature :	24 °C	Relative Humidity :	54%
Pressure :	1010 hPa	Test Date :	2012-07-16
Test Mode :	On	Polarization :	Z
Test Power :	AC 230V/50Hz		

Freq. (MHz)	Reading (dBuV)	Factor (dBuV)	Measurement (dBuV)	Limit (dBuV)	Over (dB)	Detector
0.0413	33.21	15.98	49.19	88.00	-38.81	QP
0.1269	17.73	15.35	33.08	54.56	-21.48	AVG
0.3664	6.81	10.42	17.23	47.35	-30.12	QP
1.0740	-3.00	10.45	7.45	24.54	-17.09	AVG
7.2660	-5.14	10.68	5.54	12.00	-6.46	AVG
7.8380	3.29	10.69	13.98	22.00	-8.02	QP

Remark:

1. All readings are Quasi-Peak and Average values.
2. Factor = Antenna Factor + Cable Loss - Amplifier.
3. N/A means All Data have pass Limit



3.3 HARMONICS CURRENT

3.3.1 LIMITS OF HARMONICS CURRENT

IEC 555-2					
Table - I			Table - II		
Equipment Category	Harmonic Order n	Max. Permissible Harmonic Current (in Amperes)	Equipment Category	Harmonic Order n	Max. Permissible Harmonic Current (in Amperes)
Non Portable Tools or TV Receivers	Odd Harmonics		TV Receivers	Odd Harmonics	
	3	2.30		3	0.80
	5	1.14		5	0.60
	7	0.77		7	0.45
	9	0.40		9	0.30
	11	0.33		11	0.17
	13	0.21		13	0.12
	15 ≤ n ≤ 39	0.15 · 15/n		15 ≤ n ≤ 39	0.10 · 15/n
	Even Harmonics			Even Harmonics	
	2	1.08		2	0.30
	4	0.43		4	0.15
	8	0.30			
8 ≤ n ≤ 40	0.23 · 8/n	DC	0.05		

EN 61000-3-2/IEC 61000-3-2					
Equipment Category	Max. Permissible Harmonic Current (in Amperes)	Equipment Category	Harmonic Order n	Max. Permissible Harmonic Current (in A)	Max. Permissible Harmonic Current (mA/w)
Class A	Same as Limits Specified in 4-2.1, Table - I, but only odd harmonics required	Class D	3	2.30	3.4
			5	1.14	1.9
			7	0.77	1.0
			9	0.40	0.5
			11	0.33	0.35
			13 ≤ n ≤ 39	see Table I	3.85/n

3.3.1.1 TEST PROCEDURE

a. The EUT was placed on the top of a wooden table 0.8 meters above the ground and operated to produce the maximum harmonic components under normal operating conditions.

b. The classification of EUT is according to section 5 of EN 61000-3-2. The EUT is classified as follows:

Class A: Balanced three-phase equipment, Household appliances excluding equipment as Class D, Tools excluding portable tools, Dimmers for incandescent lamps, audio equipment, equipment not specified in one of the three other classes.

Class B: Portable tools. Portable tools.; Arc welding equipment which is not professional equipment.

Class C: Lighting equipment.

Class D: Equipment having a specified power less than or equal to 600 W of the following types: Personal computers and personal computer monitors and television receivers.

c. The correspondent test program of test instrument to measure the current harmonics emanated from EUT is chosen. The measure time shall be not less than the time necessary for the EUT to be exercised.

3.3.1.2 EUT OPERATING CONDITIONS

The EUT tested system was configured as the statements of 2.3 Unless otherwise a special operating condition is specified in the follows during the testing.

3.3.1.3 TEST SETUP

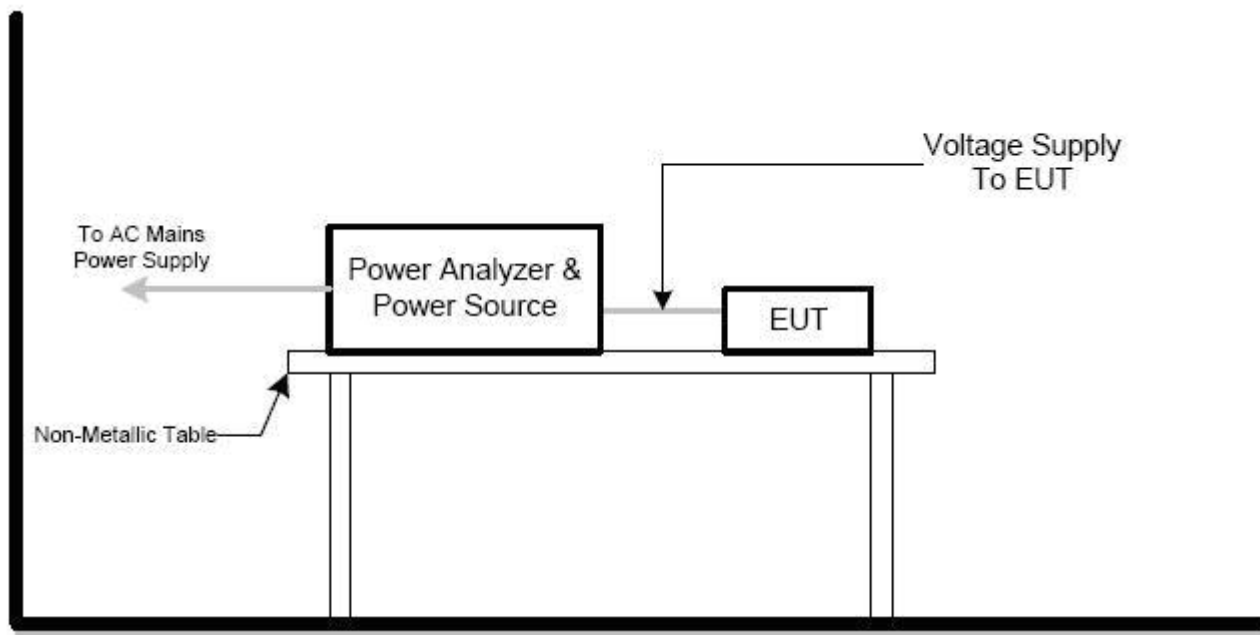

3.3.2 TEST RESULTS

EUT :	LED Power Supply	Model Name :	ELP050C1500LS
Temperature :	25 °C	Relative Humidity :	45%
Pressure :	1010 hPa	Test Date :	2012-07-17
Test Mode :	On		
Test Power :	AC 230V/50Hz		

E. U. T. Result

Harmonic(s) > 200%:	
Order (n):	None
Harmonic(s) with average > 90%:	
Order (n):	None
Harmonic(s) between 150% and 200% during more than 10% of the test time or max. 10min:	
Order (n):	None

Power Source Result

First dataset out of limit:	
DS (time):	None
Harmonic(s) out of limit:	
Order (n):	None

Average harmonic current results

Hn	leff [A]	leff [%]	Limit [A]	Result
1	25.804E-3	100.000		
2	1.055E-3	4.089	972.00E-3	PASS
3	25.376E-3	98.341	2.07	PASS
4	4.736E-3	18.355	387.00E-3	PASS
5	23.472E-3	90.962	1.03	PASS
6	1.076E-3	4.172	270.00E-3	PASS
7	20.705E-3	80.239	693.00E-3	PASS
8	1.753E-3	6.793	207.00E-3	PASS
9	17.568E-3	68.080	360.00E-3	PASS
10	1.658E-3	6.425	165.60E-3	PASS
11	14.118E-3	54.712	297.00E-3	PASS
12	917.710E-6	3.556	138.00E-3	PASS
13	10.874E-3	42.141	189.00E-3	PASS
14	886.436E-6	3.435	118.29E-3	PASS
15	7.842E-3	30.389	135.00E-3	PASS
16	844.380E-6	3.272	103.50E-3	PASS
17	5.610E-3	21.742	119.11E-3	PASS
18	1.331E-3	5.158	92.00E-3	PASS
19	4.332E-3	16.790	106.58E-3	PASS
20	785.047E-6	3.042	82.80E-3	PASS
21	3.892E-3	15.083	96.43E-3	PASS
22	1.349E-3	5.228	75.28E-3	PASS
23	3.815E-3	14.785	88.05E-3	PASS
24	705.276E-6	2.733	68.99E-3	PASS
25	3.665E-3	14.203	81.00E-3	PASS
26	1.164E-3	4.510	63.69E-3	PASS
27	3.343E-3	12.954	75.00E-3	PASS
28	687.583E-6	2.665	59.14E-3	PASS
29	2.763E-3	10.706	69.83E-3	PASS
30	725.358E-6	2.811	55.20E-3	PASS
31	2.427E-3	9.405	65.32E-3	PASS
32	739.522E-6	2.866	51.75E-3	PASS
33	1.755E-3	6.800	61.36E-3	PASS
34	691.836E-6	2.681	48.71E-3	PASS
35	1.863E-3	7.219	57.86E-3	PASS
36	697.284E-6	2.702	46.00E-3	PASS
37	1.543E-3	5.980	54.73E-3	PASS
38	631.023E-6	2.445	43.58E-3	PASS
39	1.558E-3	6.036	51.92E-3	PASS
40	1.042E-3	4.038	41.40E-3	PASS

Maximum harmonic current results

Hn	leff [A]	leff [%]	Limit [A]	Result
1	26.062E-3	100.000		
2	1.328E-3	5.097	2.16	PASS
3	25.598E-3	98.218	4.60	PASS
4	4.965E-3	19.052	860.00E-3	PASS
5	23.679E-3	90.855	2.28	PASS
6	1.320E-3	5.064	600.00E-3	PASS
7	20.842E-3	79.971	1.54	PASS
8	1.940E-3	7.444	460.00E-3	PASS
9	17.684E-3	67.853	800.00E-3	PASS
10	1.870E-3	7.176	368.00E-3	PASS
11	14.240E-3	54.641	660.00E-3	PASS
12	1.068E-3	4.096	306.66E-3	PASS
13	10.959E-3	42.048	420.00E-3	PASS
14	1.013E-3	3.885	262.86E-3	PASS
15	7.922E-3	30.397	300.00E-3	PASS
16	976.317E-6	3.746	230.00E-3	PASS
17	5.696E-3	21.856	264.70E-3	PASS
18	1.463E-3	5.614	204.44E-3	PASS
19	4.409E-3	16.916	236.84E-3	PASS
20	893.016E-6	3.426	184.00E-3	PASS
21	4.055E-3	15.559	214.28E-3	PASS
22	1.485E-3	5.698	167.28E-3	PASS
23	3.947E-3	15.146	195.66E-3	PASS
24	806.237E-6	3.094	153.32E-3	PASS
25	3.739E-3	14.347	180.00E-3	PASS
26	1.310E-3	5.027	141.54E-3	PASS
27	3.450E-3	13.237	166.66E-3	PASS
28	770.540E-6	2.957	131.42E-3	PASS
29	2.854E-3	10.951	155.18E-3	PASS
30	811.237E-6	3.113	122.66E-3	PASS
31	2.564E-3	9.836	145.16E-3	PASS
32	840.728E-6	3.226	115.00E-3	PASS
33	1.835E-3	7.040	136.36E-3	PASS
34	770.515E-6	2.956	108.24E-3	PASS
35	1.966E-3	7.543	128.58E-3	PASS
36	796.904E-6	3.058	102.22E-3	PASS
37	1.614E-3	6.192	121.62E-3	PASS
38	714.244E-6	2.741	96.84E-3	PASS
39	1.647E-3	6.318	115.38E-3	PASS
40	1.135E-3	4.355	92.00E-3	PASS

Maximum harmonic voltage results

Hn	Ueff [V]	Ueff [%]	Limit [%]	Result
1	231.41	100.614		
2	74.66E-3	0.032	0.2	PASS
3	113.01E-3	0.049	0.9	PASS
4	18.80E-3	0.008	0.2	PASS
5	35.13E-3	0.015	0.4	PASS
6	12.18E-3	0.005	0.2	PASS
7	31.28E-3	0.014	0.3	PASS
8	10.98E-3	0.005	0.2	PASS
9	33.51E-3	0.015	0.2	PASS
10	10.86E-3	0.005	0.2	PASS
11	41.80E-3	0.018	0.1	PASS
12	11.75E-3	0.005	0.1	PASS
13	29.03E-3	0.013	0.1	PASS
14	8.08E-3	0.004	0.1	PASS
15	28.48E-3	0.012	0.1	PASS
16	10.41E-3	0.005	0.1	PASS
17	20.20E-3	0.009	0.1	PASS
18	9.57E-3	0.004	0.1	PASS
19	39.86E-3	0.017	0.1	PASS
20	9.99E-3	0.004	0.1	PASS
21	30.24E-3	0.013	0.1	PASS
22	11.98E-3	0.005	0.1	PASS
23	28.59E-3	0.012	0.1	PASS
24	10.64E-3	0.005	0.1	PASS
25	12.16E-3	0.005	0.1	PASS
26	12.47E-3	0.005	0.1	PASS
27	29.55E-3	0.013	0.1	PASS
28	9.99E-3	0.004	0.1	PASS
29	31.66E-3	0.014	0.1	PASS
30	11.23E-3	0.005	0.1	PASS
31	23.50E-3	0.010	0.1	PASS
32	8.09E-3	0.004	0.1	PASS
33	11.48E-3	0.005	0.1	PASS
34	9.76E-3	0.004	0.1	PASS
35	24.81E-3	0.011	0.1	PASS
36	8.03E-3	0.003	0.1	PASS
37	21.20E-3	0.009	0.1	PASS
38	11.20E-3	0.005	0.1	PASS
39	29.07E-3	0.013	0.1	PASS
40	11.32E-3	0.005	0.1	PASS

Harmonic current results - DS: 15

Hn	I _{eff} [A]	I _{eff} [%]	Limit [A]	Result
1	25.987E-3	100.000		
2	956.289E-6	3.680	1.08	PASS
3	25.321E-3	97.439	2.30	PASS
4	4.711E-3	18.129	430.00E-3	PASS
5	23.634E-3	90.945	1.14	PASS
6	1.053E-3	4.052	300.00E-3	PASS
7	20.794E-3	80.017	770.00E-3	PASS
8	1.699E-3	6.538	230.00E-3	PASS
9	17.624E-3	67.819	400.00E-3	PASS
10	1.603E-3	6.170	184.00E-3	PASS
11	14.097E-3	54.245	330.00E-3	PASS
12	881.729E-6	3.393	153.33E-3	PASS
13	10.865E-3	41.811	210.00E-3	PASS
14	842.426E-6	3.242	131.43E-3	PASS
15	7.887E-3	30.350	150.00E-3	PASS
16	803.349E-6	3.091	115.00E-3	PASS
17	5.668E-3	21.810	132.35E-3	PASS
18	1.347E-3	5.182	102.22E-3	PASS
19	4.282E-3	16.477	118.42E-3	PASS
20	756.954E-6	2.913	92.00E-3	PASS
21	3.875E-3	14.913	107.14E-3	PASS
22	1.300E-3	5.004	83.64E-3	PASS
23	3.837E-3	14.764	97.83E-3	PASS
24	662.428E-6	2.549	76.66E-3	PASS
25	3.670E-3	14.123	90.00E-3	PASS
26	1.034E-3	3.978	70.77E-3	PASS
27	3.313E-3	12.749	83.33E-3	PASS
28	654.024E-6	2.517	65.71E-3	PASS
29	2.735E-3	10.524	77.59E-3	PASS
30	669.093E-6	2.575	61.33E-3	PASS
31	2.495E-3	9.601	72.58E-3	PASS
32	709.400E-6	2.730	57.50E-3	PASS
33	1.779E-3	6.847	68.18E-3	PASS
34	692.903E-6	2.666	54.12E-3	PASS
35	1.801E-3	6.930	64.29E-3	PASS
36	660.232E-6	2.541	51.11E-3	PASS
37	1.535E-3	5.906	60.81E-3	PASS
38	604.576E-6	2.326	48.42E-3	PASS
39	1.533E-3	5.898	57.69E-3	PASS
40	1.079E-3	4.152	46.00E-3	PASS

Caution: Results related to the 100% limit values

Harmonic voltage results - DS: 15

Hn	Ueff [V]	Ueff [%]	Limit [%]	Result
1	231.41	100.612		
2	55.78E-3	0.024	0.2	PASS
3	109.61E-3	0.048	0.9	PASS
4	14.07E-3	0.006	0.2	PASS
5	24.77E-3	0.011	0.4	PASS
6	5.37E-3	0.002	0.2	PASS
7	28.87E-3	0.013	0.3	PASS
8	6.35E-3	0.003	0.2	PASS
9	13.59E-3	0.006	0.2	PASS
10	3.01E-3	0.001	0.2	PASS
11	35.23E-3	0.015	0.1	PASS
12	8.30E-3	0.004	0.1	PASS
13	22.30E-3	0.010	0.1	PASS
14	6.62E-3	0.003	0.1	PASS
15	22.96E-3	0.010	0.1	PASS
16	4.20E-3	0.002	0.1	PASS
17	13.77E-3	0.006	0.1	PASS
18	2.04E-3	0.001	0.1	PASS
19	35.55E-3	0.015	0.1	PASS
20	4.09E-3	0.002	0.1	PASS
21	24.53E-3	0.011	0.1	PASS
22	6.30E-3	0.003	0.1	PASS
23	22.62E-3	0.010	0.1	PASS
24	7.03E-3	0.003	0.1	PASS
25	6.39E-3	0.003	0.1	PASS
26	4.66E-3	0.002	0.1	PASS
27	20.80E-3	0.009	0.1	PASS
28	4.00E-3	0.002	0.1	PASS
29	23.81E-3	0.010	0.1	PASS
30	5.98E-3	0.003	0.1	PASS
31	19.93E-3	0.009	0.1	PASS
32	3.37E-3	0.001	0.1	PASS
33	3.20E-3	0.001	0.1	PASS
34	2.40E-3	0.001	0.1	PASS
35	12.40E-3	0.005	0.1	PASS
36	5.10E-3	0.002	0.1	PASS
37	16.18E-3	0.007	0.1	PASS
38	3.97E-3	0.002	0.1	PASS
39	22.66E-3	0.010	0.1	PASS
40	3.40E-3	0.001	0.1	PASS

Power and THD results - DS: 15

True power P:	53.17W	Apparent power S:	62.96VA
Reactiv power Q:	11.48var	Power factor:	0.912
THD (U):	0.001	THD (I):	1.903
Crest Factor (U):	1.414	Crest Factor (I):	3.932

3.4 VOLTAGE FLUCTUATION AND FLICKERS

3.4.1 LIMITS OF VOLTAGE FLUCTUATION AND FLICKERS

Tests	Limits		Descriptions
	IEC555-3	IEC/EN 61000-3-3	
Pst	≤ 1.0, Tp= 10 min.	≤ 1.0, Tp= 10 min.	Short Term Flicker Indicator
Plt	N/A	≤ 0.65, Tp=2 hr.	Long Term Flicker Indicator
dc	≤ 3%	≤ 3.3%	Relative Steady-State V-Chang
dmax	≤ 4%	≤ 4%	Maximum Relative V-change
d (t)	N/A	≤ 3.3% for > 500 ms	Relative V-change characteristic

3.4.1.1 TEST PROCEDURE

a. Harmonic Current Test:

Test was performed according to the procedures specified in Clause 5.0 of IEC555-2 and/or Sub-clause 6.2 of IEC/EN 61000-3-2 depend on which standard adopted for compliance measurement.

b. Fluctuation and Flickers Test:

Tests was performed according to the Test Conditions/Assessment of Voltage Fluctuations specified in Clause 5.0/6.0 of IEC555-3 and/or Clause 6.0/4.0 of IEC/EN 61000-3-3 depend on which standard adopted for compliance measurement.

c. All types of harmonic current and/or voltage fluctuation in this report are assessed by direct measurement using flicker-meter.

3.4.1.2 EUT OPERATING CONDITIONS

The EUT tested system was configured as the statements of 2.3 Unless otherwise a special operating condition is specified in the follows during the testing.

3.4.1.3 TEST SETUP

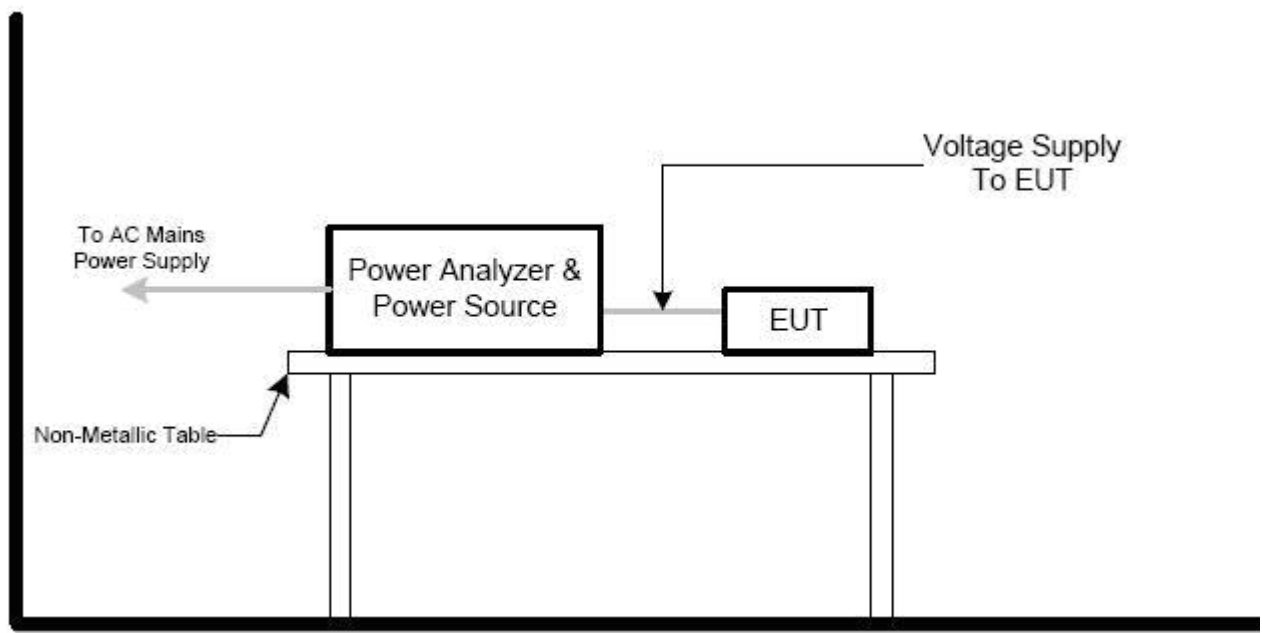

3.4.2 TEST RESULTS

EUT:	LED Power Supply	Model Name :	ELP050C1500LS
Temperature :	25 °C	Relative Humidity :	45%
Pressure :	1010 hPa	Test Date :	2012-07-17
Test Mode :	On		
Test Power :	AC 230V/50Hz		

Maximum Flicker results

	EUT values	Limit	Result
Pst	0.028	1.00	PASS
Plt	0.028	0.65	PASS
dc [%]	0.005	3.30	PASS
dmax [%]	0.073	4.00	PASS
dt [s]	0.000	0.50	PASS

4. EMC IMMUNITY TEST

4.1 STANDARD COMPLIANCE/SERVIRITY LEVEL/CRITERIA

Tests Standard No.	TEST SPECIFICATION Level	Test Mode Test Ports	Perform. Criteria
1. ESD IEC/EN 61000-4-2	8KV air discharge 4KV contact discharge	Direct Mode	B
	4KV HCP discharge 4KV VCP discharge	Indirect Mode	B
2. RS IEC/EN 61000-4-3	80 MHz to 1000 MHz 1000Hz, 80%, AM modulated	Enclosure	A
3. EFT/Burst IEC/EN 61000-4-4	5/50ns Tr/Th 5KHz Repetition Freq.	Power Supply Port	B
	5/50ns Tr/Th 5KHz Repetition Freq.	CTL/Signal Data Line Port	B
4. Surges IEC/EN 61000-4-5	1.2/50(8/20) Tr/Th us	L-N	B
	1.2/50(8/20) Tr/Th us	L-PE N-PE	B
5 Injected Current IEC/EN 61000-4-6	0.15 MHz to 80 MHz, 1000Hz 80% , AM Modulated 150Ω source impedance	CTL/Signal Port	A
	0.15 MHz to 80 MHz, 1000Hz 80% , AM Modulated 150Ω source impedance	AC Power Port	A
	0.15 MHz to 80 MHz, 1000Hz 80% , AM Modulated 150Ω source impedance	DC Power Port	A
6. Power Frequency Magnetic Field IEC/EN 61000-4-8	50 Hz,	Enclosure	A
7. Volt. Interruptions Volt. Dips IEC/EN 61000-4-11	Voltage dip 100%	AC Power Port	B
	Voltage dip 30%		C

4.2 GENERAL PERFORMANCE CRITERIA

According to **EN 61547** standard, the general performance criteria as following:

<p>Criterion A</p>	<p>The equipment shall continue to operate as intended without operator intervention. No degradation of performance or loss of function is allowed below a performance level specified by the manufacturer when the equipment is used as intended.</p> <p>The performance level may be replaced by a permissible loss of performance. If the minimum performance level or the permissible performance loss is not specified by the manufacturer, then either of these may be derived from the product description and documentation, and by what the user may reasonably expect from the equipment if used as intended.</p>
<p>Criterion B</p>	<p>After the test, the equipment shall continue to operate as intended without operator intervention. No degradation of performance or loss of function is allowed, after the application of the phenomena below a performance level specified by the manufacturer, when the equipment is used as intended.</p> <p>The performance level may be replaced by a permissible loss of performance. During the test, degradation of performance is allowed. However, no change of operating state or stored data is allowed to persist after the test.</p>
<p>Criterion C</p>	<p>Loss of function is allowed, provided the function is self-recoverable, or can be restored by the operation of the controls by the user in accordance with the manufacturer's instructions.</p> <p>Functions, and/or information stored in non-volatile memory, or protected by a battery backup, shall not be lost.</p>

4.3 GENERAL PERFORMANCE CRITERIA TEST SETUP

The EUT tested system was configured as the statements of **2.3** Unless otherwise a special operating condition is specified in the follows during the testing.

4.4 ESD TESTING

4.4.1 TEST SPECIFICATION

Basic Standard:	IEC/EN 61000-4-2
Discharge Impedance:	330 ohm / 150 pF
Required Performance	B
Discharge Voltage:	Air Discharge : 2kV/4kV/8kV (Direct) Contact Discharge : 2kV/4kV (Direct/Indirect)
Polarity:	Positive & Negative
Number of Discharge:	Air Discharge: min. 20 times at each test point Contact Discharge: min. 200 times in total
Discharge Mode:	Single Discharge
Discharge Period:	1 second minimum

4.4.2 TEST PROCEDURE

The test generator necessary to perform direct and indirect application of discharges to the EUT in the following manner:

- a. Contact discharge was applied to conductive surfaces and coupling planes of the EUT.

During the test, it was performed with single discharges. For the single discharge time between successive single discharges was at least 1 second. The EUT shall be exposed to at least 200 discharges, 100 each at negative and positive polarity, at a minimum of four test points. One of the test points shall be subjected to at least 50 indirect discharges to the center of the front edge of the horizontal coupling plane. The remaining three test points shall each receive at least 50 direct contact discharges.

If no direct contact test points are available, then at least 200 indirect discharges shall be applied in the indirect mode. Test shall be performed at a maximum repetition rate of one discharge per second.

Vertical Coupling Plane (VCP):
The coupling plane, of dimensions 0.5m x 0.5m, is placed parallel to, and positioned at a distance 0.1m from, the EUT, with the Discharge Electrode touching the coupling plane. The four faces of the EUT will be performed with electrostatic discharge.

Horizontal Coupling Plane (HCP):
The coupling plane is placed under to the EUT. The generator shall be positioned vertically at a distance of 0.1m from the EUT, with the Discharge Electrode touching the coupling plane. The four faces of the EUT will be performed with electrostatic discharge.
- b. Air discharges at insulation surfaces of the EUT.

It was at least ten single discharges with positive and negative at the same selected point.

4.4.3 TEST SETUP

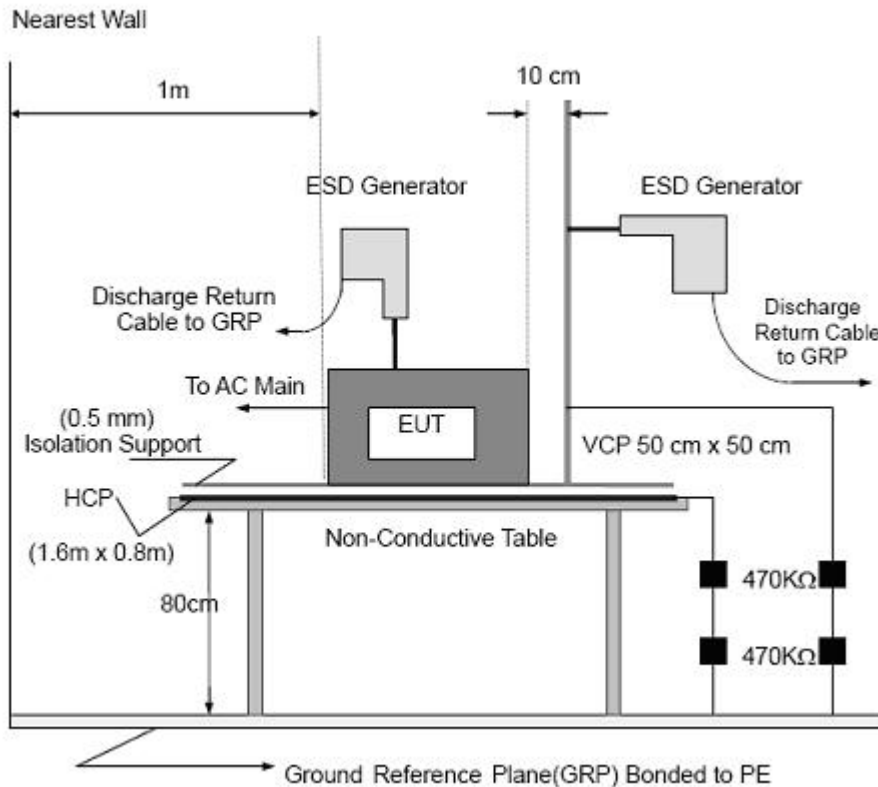

Note:

TABLE-TOP EQUIPMENT

The configuration consisted of a wooden table 0.8 meters high standing on the Ground Reference Plane. The GRP consisted of a sheet of aluminum at least 0.25mm thick, and 2.5 meters square connected to the protective grounding system. A Horizontal Coupling Plane (1.6m x 0.8m) was placed on the table and attached to the GRP by means of a cable with 940k total impedance. The equipment under test, was installed in a representative system as described in section 7 of IEC /EN 61000-4-2, and its cables were placed on the HCP and isolated by an insulating support of 0.5mm thickness. A distance of 1-meter minimum was provided between the EUT and the walls of the laboratory and any other metallic structure.

FLOOR-STANDING EQUIPMENT

The equipment under test was installed in a representative system as described in section 7 of IEC/EN 61000-4-2, and its cables were isolated from the Ground Reference Plane by an insulating support of 0.1-meter thickness. The GRP consisted of a sheet of aluminum that is at least 0.25mm thick, and 2.5meters square connected to the protective grounding system and extended at least 0.5 meters from the EUT on all sides.

4.4.4 TEST RESULTS

EUT :	LED Power Supply	Model Name :	ELP050C1500LS
Temperature :	25 °C	Relative Humidity :	45%
Pressure :	1010 hPa	Test Date :	2012-07-17
Test Mode :	On		
Test Power :	AC 230V/50Hz		

Mode	Air Discharge								Contact Discharge								Criterion	Result
	4		8		10		15		2		4		6		8			
Test level (kV)																		
Test Location	+	-	+	-	+	-	+	-	+	-	+	-	+	-	+	-		
HCP									A	A	A	A					B	PASS
VCP									A	A	A	A						PASS
A1	A	A	A	A														PASS
C1									A	A	A	A						PASS

Note:

- 1) +/- denotes the Positive/Negative polarity of the output voltage.
- 2) Test condition:
 Direct / Indirect (HCP/VCP) discharges: Minimum 50 times (Positive/Negative) at each point. Air discharges: Minimum 10 times (Positive/Negative) at each point.
- 3) Test location(s) in which discharge (Air and contact discharge) to be applied illustrated by photos shown in next page(s)
- 4) The Indirect (HCP/VCP) discharges description of test point as following:
 1.left side 2.right side 3.front side 4.rear side
- 5) N/A - denotes test is not applicable in this test report

4.4.5 PHOTO(S) SHOWN THE LOCATION(S) OF ESD EVALUATED



4.5 RS TESTING

4.5.1 TEST SPECIFICATION

Basic Standard:	IEC/EN 61000-4-3
Required Performance	A
Frequency Range:	80 MHz - 1000 MHz
Field Strength:	3 V/m
Modulation:	1kHz Sine Wave, 80%, AM Modulation
Frequency Step:	1 % of fundamental
Polarity of Antenna:	Horizontal and Vertical
Test Distance:	3 m
Antenna Height:	1.5 m
Dwell Time:	at least 3 seconds

4.5.2 TEST PROCEDURE

The EUT and support equipment, which are placed on a table that is 0.8 meter above ground and the testing was performed in a fully-anechoic chamber.

The testing distance from antenna to the EUT was 3 meters.

The other condition as following manner:

- a. The frequency range is swept from 80 MHz to 1000 MHz, & 1400MHz - 2700MHz with the signal 80%amplitude modulated with a 1kHz sine wave. The rate of sweep did not exceed 1.5x 10⁻³ decade/s. Where the frequency range is swept incrementally, the step size was 1% of fundamental.
- b. Sweep Frequency 900 MHz, with the Duty Cycle:1/8 and Modulation: Pulse 217 Hz(if applicable)
- c. The dwell time at each frequency shall be not less than the time necessary for the EUT to be able to respond.
- d. The test was performed with the EUT exposed to both vertically and horizontally polarized fields on each of the four sides.

4.5.3 TEST SETU

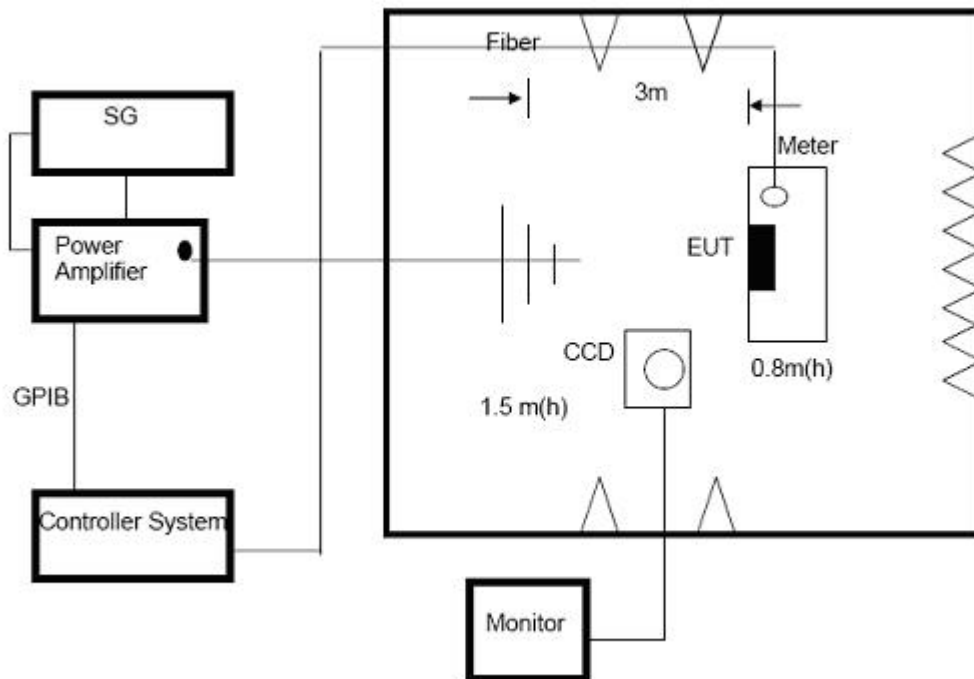

Note:

TABLE-TOP EQUIPMENT

The EUT installed in a representative system as described in section 7 of IEC/EN 61000-4-3 was placed on a non-conductive table 0.8 meters in height. The system under test was connected to the power and signal wire according to relevant installation instructions.

FLOOR-STANDING EQUIPMENT

The EUT installed in a representative system as described in section 7 of IEC/EN 61000-4-3 was placed on a non-conductive wood support 0.1 meters in height. The system under test was connected to the power and signal wire according to relevant installation instructions.

4.5.4 TEST RESULTS

EUT :	LED Power Supply	Model Name :	ELP050C1500LS
Temperature :	25 °C	Relative Humidity :	60%
Pressure :	1010 hPa	Test Date :	2012-07-17
Test Mode :	On		
Test Power :	AC 230V/50Hz		

Frequency Range (MHz)	RF Field Position	R.F. Field Strength	Azimuth	Perform. Criteria	Results	Judgment
80MHz - 1000MHz	H / V	3 V/m (rms) AM Modulated 1000Hz, 80%	Front	A	A	PASS
			Rear			
			Left			
			Right			

Note:

- 1) N/A - denotes test is not applicable in this test report.
- 2) Criteria A: There was no change operated with initial operating during the test.
- 3) Criteria B: The EUT function loss during the test, but self-recoverable after the test.
- 4) Criteria C: The system shut down during the test.

4.6 EFT/BURST TESTING

4.6.1 TEST SPECIFICATION

Basic Standard:	IEC/EN 61000-4-4
Required Performance	B
Test Voltage:	Power Line : 1 kV Signal/Control Line : 0.5 KV
Polarity:	Positive & Negative
Impulse Frequency:	5 kHz
Impulse Wave shape :	5/50 ns
Burst Duration:	15 ms
Burst Period:	300 ms
Test Duration:	Not less than 1 min.

4.6.2 TEST PROCEDURE

The EUT and support equipment, are placed on a table that is 0.8 meter above a metal ground plane measured 1m*1m min. and 0.65mm thick min.

The other condition as following manner:

- a. The length of power cord between the coupling device and the EUT should not exceed 1 meter.
- b. Both positive and negative polarity discharges were applied.
- c. The duration time of each test sequential was 1 minute

4.6.3 TEST SETUP

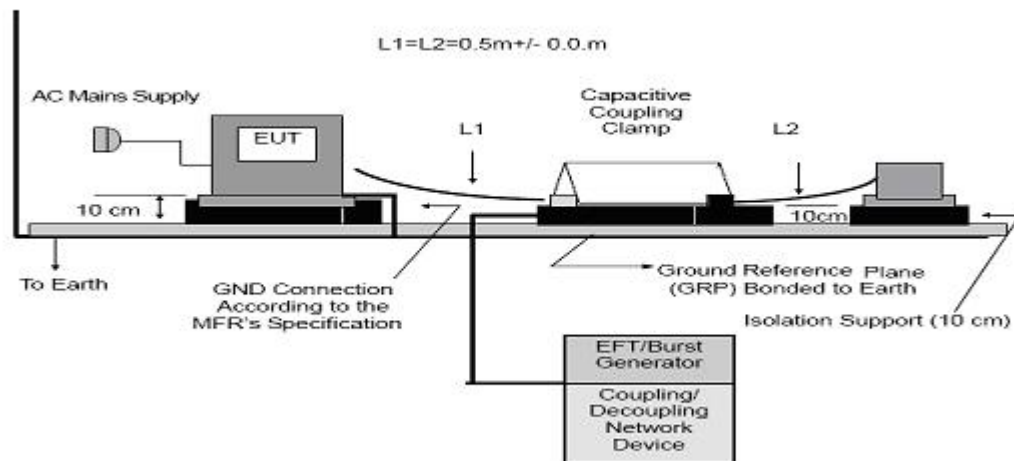
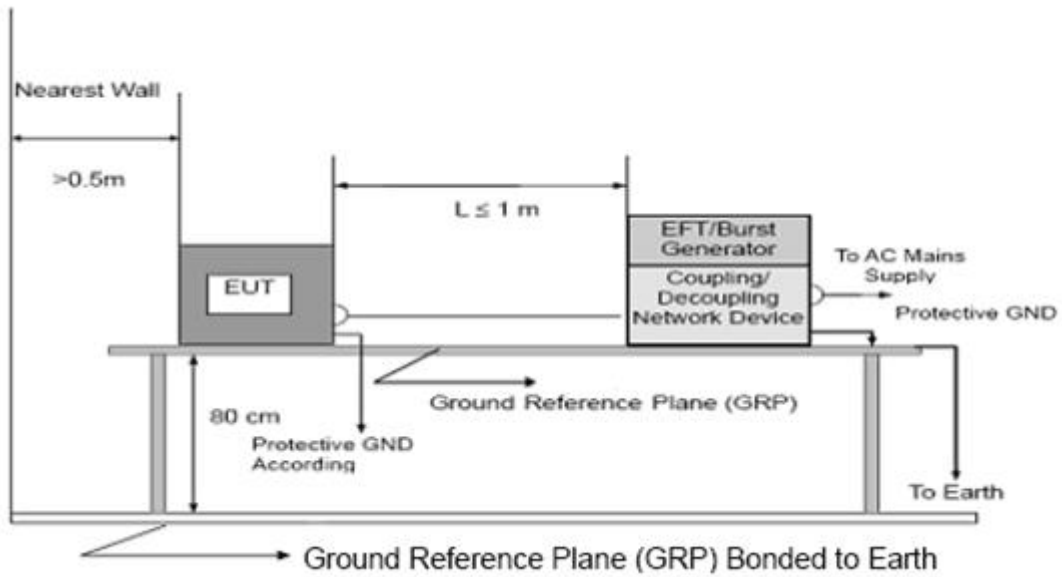

Note:

TABLE-TOP EQUIPMENT

The configuration consisted of a wooden table (0.8m high) standing on the Ground Reference Plane. The GRP consisted of a sheet of aluminum (at least 0.25mm thick and 2.5m square) connected to the protective grounding system. A minimum distance of 0.5m was provided between the EUT and the walls of the laboratory or any other metallic structure.

FLOOR-STANDING EQUIPMENT

The EUT installed in a representative system as described in section 7 of IEC/EN 61000-4-4 and its cables, were isolated from the Ground Reference Plane by an insulating support that is 0.1-meter thick. The GRP consisted of a sheet of aluminum (at least 0.25mm thick and 2.5m square) connected to the protective grounding system.

4.6.4 TEST RESULTS

EUT :	LED Power Supply	Model Name :	ELP050C1500LS
Temperature :	25 °C	Relative Humidity :	60%
Pressure :	1010 hPa	Test Date :	2012-07-17
Test Mode :	On		
Test Power :	AC 230V/50Hz		

Coupling Line		Test level (kV)								Criterion	Result
		0.5		1		2		4			
		+	-	+	-	+	-	+	-		
AC line	L	A	A	A	A					B	PASS
	N	A	A	A	A						PASS
	PE										
	L+N	A	A	A	A						PASS
	L+PE										
	N+PE										
	L+N+PE										
DC Line											
Signal Line											

Note:

- 1) +/- denotes the Positive/Negative polarity of the output voltage.
- 2) N/A - denotes test is not applicable in this test report
- 3) Criteria A: There was no change operated with initial operating during the test.
- 4) Criteria B: The EUT function loss during the test, but self-recoverable after the test.
- 5) Criteria C: The system shut down during the test.

4.7 SURGE TESTING

4.7.1 TEST SPECIFICATION

Basic Standard:	IEC/EN 61000-4-5
Required Performance	B
Wave-Shape:	Combination Wave 1.2/50 us Open Circuit Voltage 8 /20 us Short Circuit Current
Test Voltage:	Power Line : 0.5 kV, 1 kV, 2 kV
Surge Input/Output:	L-N, L-PE, N-PE
Generator Source:	2 ohm between networks
Impedance:	12 ohm between network and ground
Polarity:	Positive/Negative
Phase Angle:	0 /90/180/270°
Pulse Repetition Rate:	1 time / min. (maximum)
Number of Tests:	5 positive and 5 negative at selected points

4.7.2 TEST PROCEDURE

a. For EUT power supply:

The surge is to be applied to the EUT power supply terminals via the capacitive coupling network. Decoupling networks are required in order to avoid possible adverse effects on equipment not under test that may be powered by the same lines, and to provide sufficient decoupling impedance to the surge wave. The power cord between the EUT and the coupling/decoupling networks shall be 2meters in length (or shorter).

b. For test applied to unshielded unsymmetrically operated interconnection lines of EUT:

The surge is applied to the lines via the capacitive coupling. The coupling /decoupling networks shall not influence the specified functional conditions of the EUT. The interconnection line between the EUT and the coupling/decoupling networks shall be 2 meters in length (or shorter).

c. For test applied to unshielded symmetrically operated interconnection /telecommunication lines of EUT:

d. The surge is applied to the lines via gas arrestors coupling. Test levels below the ignition point of the coupling arrestor cannot be specified. The interconnection line between the EUT and the coupling/decoupling networks shall be 2 meters in length (or shorter).

4.7.3 TEST SETUP

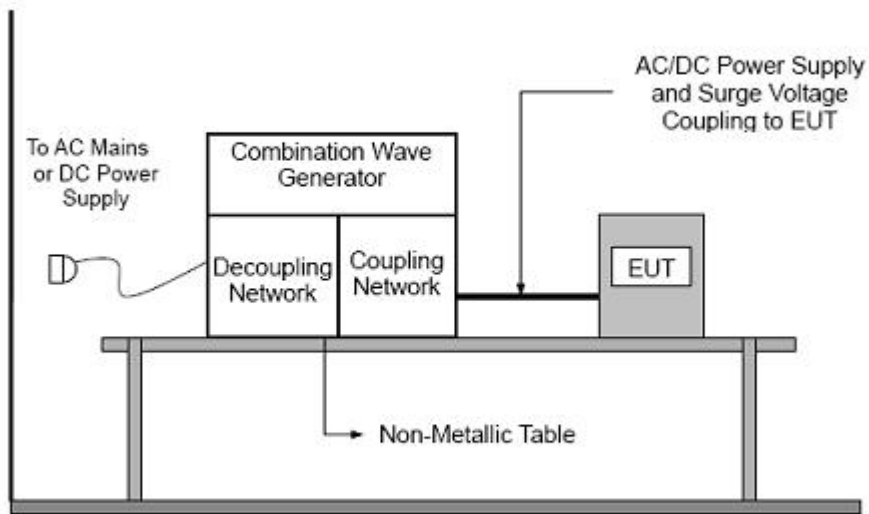

4.7.4 TEST RESULTS

EUT :	LED Power Supply	Model Name :	ELP050C1500LS
Temperature :	25 °C	Relative Humidity :	60%
Pressure :	1010 hPa	Test Date :	2012-07-17
Test Mode :	On		
Test Power :	AC 230V/50Hz		

Coupling Line			Test level								Criterion	Result
			0.5 kV		1 kV		2 kV		4 kV			
			+	-	+	-	+	-	+	-		
AC line	L-N	0°	A	A	A	A					B	PASS
		90°	A	A	A	A						
		180°	A	A	A	A						
		270°	A	A	A	A						
	L-PE	0°										
		90°										
		180°										
		270°										
	N-PE	0°										
		90°										
		180°										
		270°										
DC Line												
Signal Line												

Note:

- 1) Polarity and Numbers of Impulses : 5 Pst / Ngst at each tested mode
- 2) N/A - denotes test is not applicable in this Test Report
- 3) Criteria A: There was no change operated with initial operating during the test.
- 4) Criteria B: The EUT function loss during the test, but self-recoverable after the test.
- 5) Criteria C: The system shut down during the test.

4.8 INJECTION CURRENT TESTING

4.8.1 TEST SPECIFICATION

Basic Standard:	IEC/EN 61000-4-6
Required Performance	A
Frequency Range:	0.15 MHz - 80 MHz
Field Strength:	3 Vr.m.s.
Modulation:	1kHz Sine Wave, 80%, AM Modulation
Frequency Step:	1 % of fundamental
Dwell Time:	at least 3 seconds

4.8.2 TEST PROCEDURE

The EUT and support equipment, are placed on a table that is 0.8 meter above a metal ground plane measured 1m*1m min. and 0.65mm thick min.

The other condition as following manner:

- a. The frequency range is swept from 150 KHz to 80 MHz, with the signal 80%amplitude modulated with a 1kHz sine wave. The rate of sweep did not exceed 1.5×10^{-3} decade/s. Where the frequency range is swept incrementally, the step size was 1% of fundamental.
- b. The dwell time at each frequency shall be not less than the time necessary for the EUT to be able to respond.

4.8.3 TEST SETUP

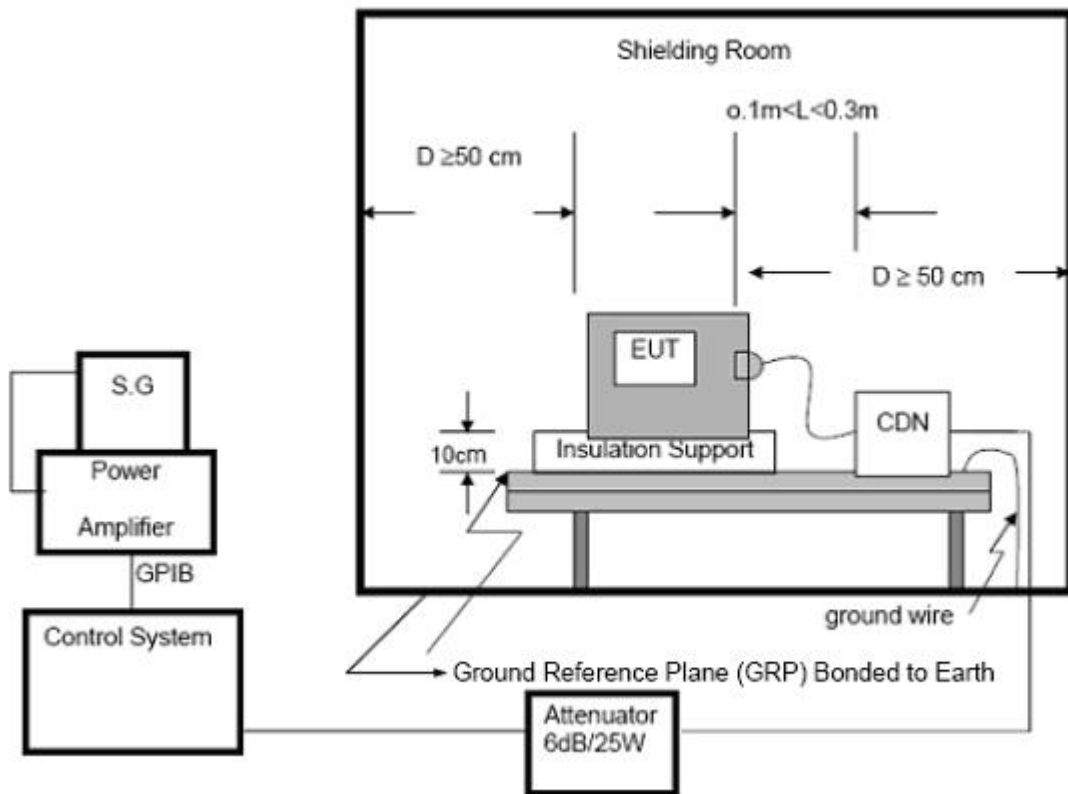

NOTE:

FLOOR-STANDING EQUIPMENT

The equipment to be tested is placed on an insulating support of 0.1 meters height above a ground reference plane. All relevant cables shall be provided with the appropriate coupling and decoupling devices at a distance between 0.1 meters and 0.3 meters from the projected geometry of the EUT on the ground reference plane.

4.8.4 TEST RESULTS

EUT :	LED Power Supply	Model Name :	ELP050C1500LS
Temperature :	25 °C	Relative Humidity :	60%
Pressure :	1010 hPa	Test Date :	2012-07-16
Test Mode :	On		
Test Power :	AC 230V/50Hz		

Test Ports (Mode)	Freq. Range (MHz)	Field Strength	Perform. Criteria	Results	Judgment
Input/ Output AC. Power Port	0.15 ---80	3V(rms) AM Modulated 1000Hz, 80%	A	A	PASS
Input/ Output DC. Power Port	0.15 --- 80		A	N/A	N/A
Signal Line	0.15 --- 80		A	N/A	N/A

Note:

- 1) N/A - denotes test is not applicable in this Test Report.
- 2) Criteria A: There was no change operated with initial operating during the test.
- 3) Criteria B: The EUT function loss during the test, but self-recoverable after the test.
- 4) Criteria C: The system shut down during the test.

4.9 POWER FREQUENCY MAGNETIC FIELD TESTING

4.9.1 TEST SPECIFICATION

Basic Standard:	IEC/EN 61000-4-8
Required Performance	A
Frequency Range:	50Hz
Field Strength:	3 A/m
Observation Time:	1 minute
Inductance Coil:	Rectangular type, 1mx1m

4.9.2 TEST PROCEDURE

The EUT and support equipment, are placed on a table that is 0.8 meter above a metal ground plane measured 1m*1m min. and 0.65mm thick min.

The other condition as following manner:

- a. The equipment cabinets shall be connected to the safety earth directly on the GRP via the earth terminal of the EUT.
- b. The cables supplied or recommended by the equipment manufacturer shall be used. 1 meter of all cables used shall be exposed to the magnetic field.

4.9.3 TEST SETUP

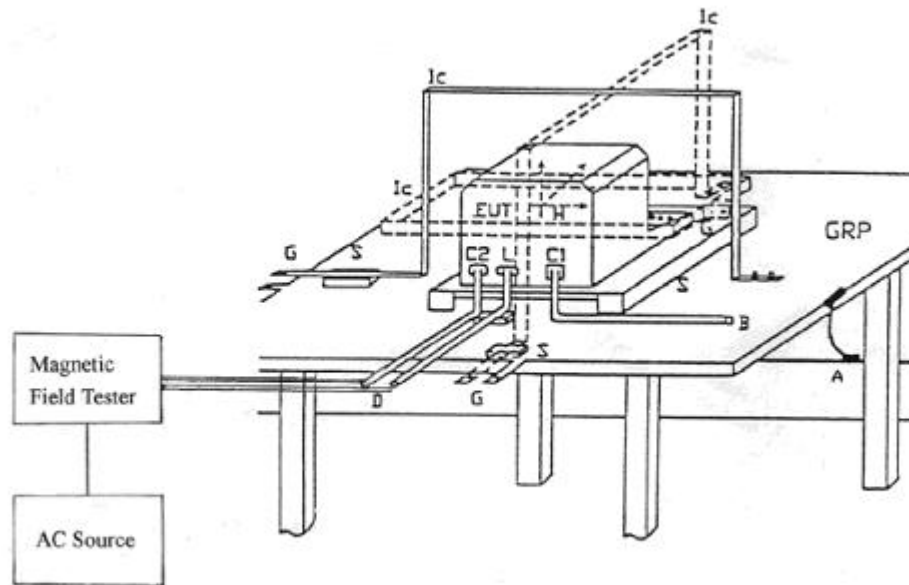

Note:

TABLE-TOP EQUIPMENT

The equipment shall be subjected to the test magnetic field by using the induction coil of standard dimension (1 m x 1 m). The induction coil shall then be rotated by 90 degrees in order to expose the EUT to the test field with different orientations.

FLOOR-STANDING EQUIPMENT

The equipment shall be subjected to the test magnetic field by using induction coils of suitable dimensions. The test shall be repeated by moving and shifting the induction coils, in order to test the whole volume of the EUT for each orthogonal direction. The test shall be repeated with the coil shifted to different positions along the side of the EUT, in steps corresponding to 50 % of the shortest side of the coil. The induction coil shall then be rotated by 90 degrees in order to expose the EUT to the test field with different orientations.

4.9.4 TEST RESULTS

EUT :	LED Power Supply	Model Name :	ELP050C1500LS
Temperature :	25 °C	Relative Humidity :	60%
Pressure :	1010 hPa	Test Date :	2012-07-17
Test Mode :	On		
Test Power :	AC 230V/50Hz		

Test Mode	Test Level	Antenna aspect	Duration (s)	Perform Criteria	Results	Judgment
Enclosure	3 A/m	X	300 s	A	A	Pass
Enclosure	3 A/m	Y	300 s	A	A	Pass
Enclosure	3 A/m	Z	300 s	A	A	Pass

Note:

- 1) N/A - denotes test is not applicable in this test report
- 2) Criteria A: There was no change operated with initial operating during the test.
- 3) Criteria B: The EUT function loss during the test, but self-recoverable after the test.
- 4) Criteria C: The system shut down during the test.

4.10 VOLTAGE INTERRUPTION/DIPS TESTING

4.10.1 TEST SPECIFICATION

Basic Standard:	IEC/EN 61000-4-11
Required Performance	B (For 100% Voltage Dips) C (For 30% Voltage Dips)
Test Duration Time:	Minimum three test events in sequence
Interval between Event:	Minimum ten seconds
Phase Angle:	0°/45°/90°/135°/180°/225°/270°/315°/360°
Test Cycle:	3 times

4.10.2 TEST PROCEDURE

The EUT shall be tested for each selected combination of test levels and duration with a sequence of three dips/interruptions with intervals of 10 s minimum (between each test event). Each representative mode of operation shall be tested. Abrupt changes in supply voltage shall occur at zero crossings of the voltage waveform.

4.10.3 TEST SETUP

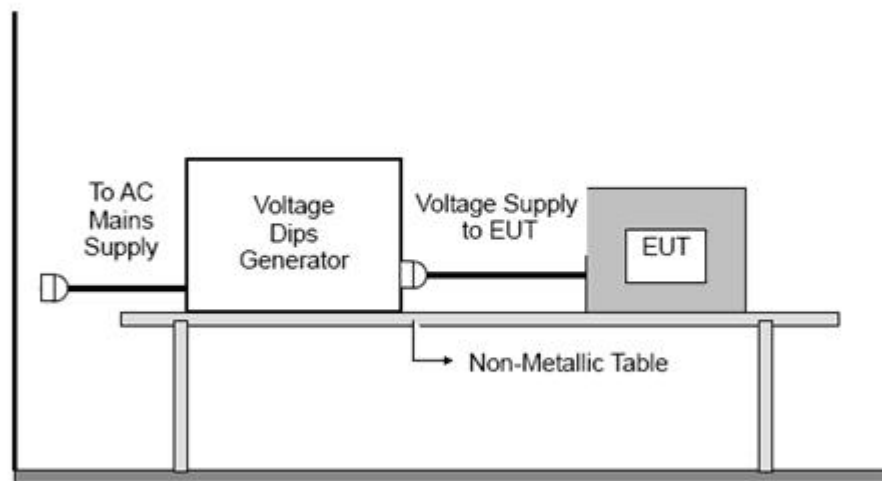

4.10.4 TEST RESULTS

EUT :	LED Power Supply	Model Name :	ELP050C1500LS
Temperature :	25 °C	Relative Humidity :	60%
Pressure :	1010 hPa	Test Date :	2012-07-16
Test Mode :	On		
Test Power :	AC 230V/50Hz		

Interruption & Dips	Duration (T)	Perform Criteria	Results	Judgment
Voltage dip 0%	0.5	B	B	PASS
Voltage dip70%	10	C	B	PASS

Note:

- 1). N/A - denotes test is not applicable in this test report.
- 2) Criteria A: There was no change operated with initial operating during the test.
- 3) Criteria B: The EUT function loss during the test, but self-recoverable after the test.
- 4) Criteria C: The system shut down during the test.

5. EUT TEST PHOTO

Radiated Measurement Photos

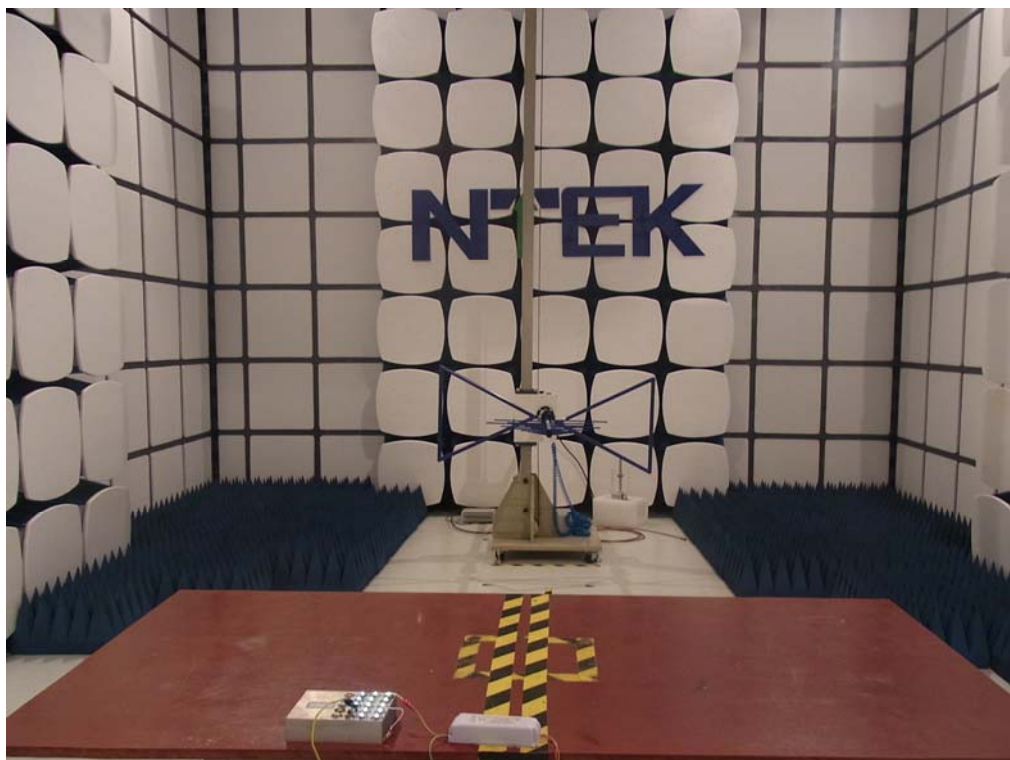
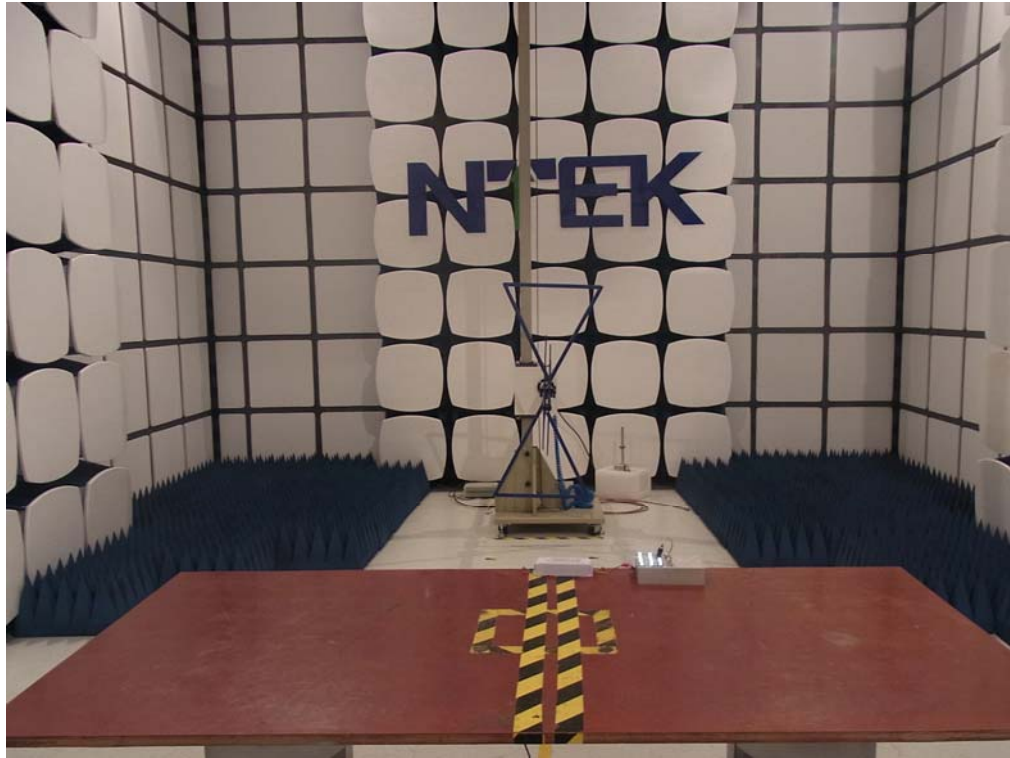

Radiated Measurement Photos



Conducted Measurement Photos

